

# SECTION A

## PARTS IDENTIFICATION - BASE ENGINE

In order to provide a simple method of identification, all models included herein have been assigned a "code" letter as follows:

ENGINE CODE	CU./IN	No.CYLS.	YEARS	IDENTIFICATION
E	- 242	4	2/65-11/69	With cylinder liners
F	363	6	2/65-11/69	With cylinder liners
G	254	4	12/69-up	Less cylinder liners
H	380	6	12/69-up	Less cylinder liners
I	363	6	7/68-up	Turbocharged

For ease in locating part numbers, turn to the applicable page:

Alternator	-----	see section B
Bearings, main and rod	-----	page A6
Block, engine	-----	A3
Camshaft	-----	A6
Crankshaft	-----	A6
Damper, crankshaft	-----	A13
Filter, fuel	-----	A22-A23
Flywheel	-----	A9
Gasket kit, engine	-----	A3
Head, cylinder	-----	A5
Injection equipment:		
Injectors	-----	A28
Pipes	-----	A20
Pump	-----	A24-A25
Pistons	-----	A6
Pulley, crankshaft	-----	A13
Pump, fuel (lift)	-----	A29
Pump, oil	-----	A12
Pump, water	-----	A31
Starting motor	-----	A33
Sump (oil pan)	-----	A14-A15
Tools	-----	A2
Turbocharger	-----	A35
Valves	-----	A10

By reference to the drawings on the applicable page, select the required part and note the "key" number assigned to it. The key number will be repeated in the first column of a following page. The second column will indicate the engine to which the part applies per the engine code letters shown above. The third column shows the quantity required per engine.





The fourth "code" column indicates the manufacturer of the subject part per the following:

CODE	MANUFACTURER
F	Ford Motor Company
T	Jabsco Pump Company
L	Lehman Power Corporation
P	Paragon Gear Works
S	Simms or CAV (Jos. Lucas Co.)
W	Warner Gear
BY	Motorola, Inc.

SERVICE MANUALS FOR ENGINES AND TRANSMISSIONS ARE LISTED AT END OF SECTION B

WHEN ORDERING PARTS SEE INSTRUCTIONS ON PAGE 2

## FORD SERVICE TOOLS

KEY	ENGINE	QUAN	CODE	PART NO.	DESCRIPTION	
-	ALL	1	F	1713504	TOOL FOR REMOVING INJECTORS. (SEE PAGE 29)	
-	ALL	1	F	8A1	WRENCH FOR FUEL INJECTION PIPE NUTS (TOP OF INJECTION PUMP)	
-	ALL	1	F	8A2	SOCKET TOOL - DELIVERY VALVE HOLDER	
-	ALL	1	F	8A3	FRONT SEAL (TIMING COVER) CENTRALIZING TOOL	
-	ALL	1	F	8A4	TOOL FOR SETTING INJECTION PUMP TIMING. (SEE PAGE 18)	

## CYLINDER BLOCK ASSEMBLY

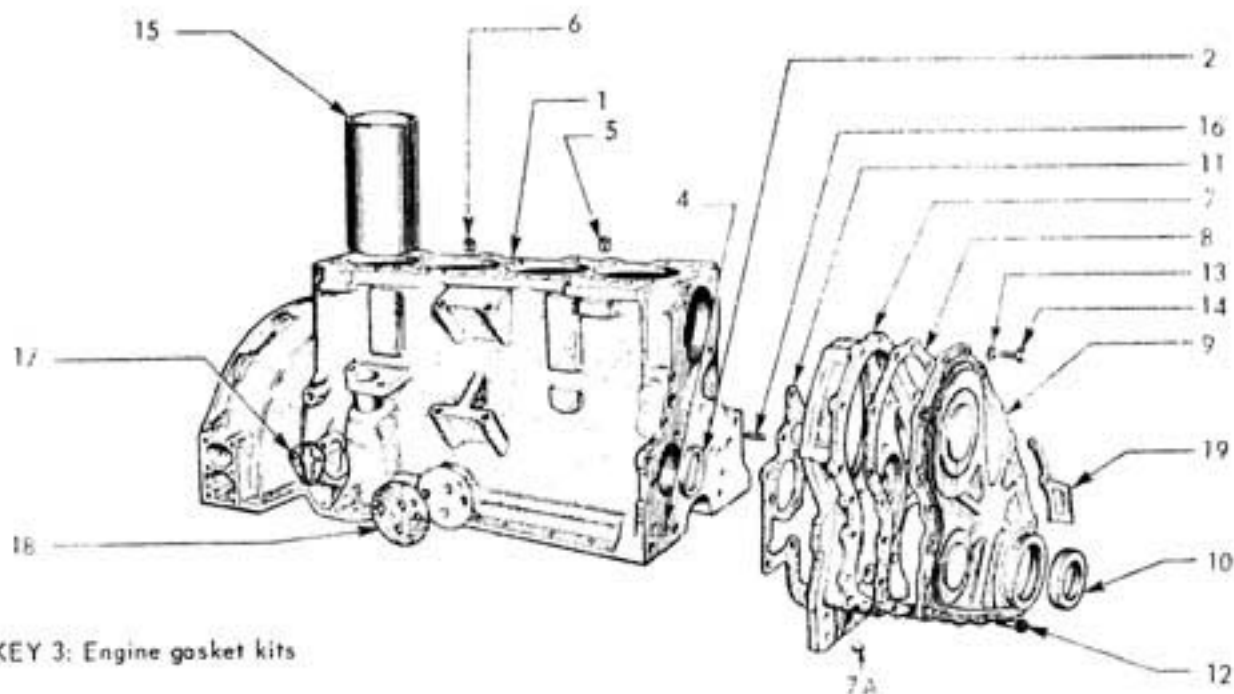

KEY 3: Engine gasket kits

KEY	ENGINE	QUAN	CODE	PART NO.	DESCRIPTION	NOTES
1	E	1	F	1460397	BLOCK, ENGINE	NOTE 1
1	F	1	F	1460401	BLOCK, ENGINE	NOTE 1
1	G	1	F	1468409	BLOCK, ENGINE	
1	H	1	F	1447612	BLOCK, ENGINE	
1	I	1	F	1527930	BLOCK, ENGINE	
1	E	1	F	1463880	CYL ASS. C/W CRANKSHAFT & PISTONS	
1	F	1	F	1460404	CYL ASS. C/W CRANKSHAFT & PISTONS	NOTE 1
1	G	1	F	1605072	CYL ASS. C/W CRANKSHAFT & PISTONS	
1	H	1	F	6073183	CYL ASS. C/W CRANKSHAFT & PISTONS	
1	I	1	F	1599335	CYL ASS. C/W CRANKSHAFT & PISTONS	
2	ALL	1	F	1788785	SLEEVE, FRONT, STD. (2/65-1/68)	
2	ALL	1	F	1746786	SLEEVE, FRONT, .020" o/s (2/65-1/68)	
2	ALL	1	F	1419959	SLEEVE, FRONT, STD. (1/68-UP)	
2	ALL	1	F	1419960	SLEEVE, FRONT, .020" o/s (1/68-UP)	
3	EG	1	F	1463786	TOP ENGINE O'HAUL GASKET KIT	
	EG	1	F	1428990	SUMP GASKET KIT	
	EG	1	F	1579279	MISCL. GASKET KIT	
	F	1	F	1444135	TOP ENGINE O'HAUL GASKET KIT	
	F	1	F	1428991	SUMP GASKET KIT	
	F	1	F	1579279	MISCL. GASKET KIT	
	H	1	F	1575292	TOP ENGINE O'HAUL GASKET KIT	
	H	1	F	1428991	SUMP GASKET KIT	
	H	1	F	1579279	MISCL. GASKET KIT	
	I	1	F	1575293	TOP ENGINE O'HAUL GASKET KIT	
	I	1	F	1428991	SUMP GASKET KIT	
	I	1	F	1579279	MISCL. GASKET KIT	

NOTE 1: WHEN USING THIS PART, ORDER NEW SUMP TO OIL PUMP TUBE AND 1426698 SEAL.

KEY	ENGINE	QTY	CODE	PART NO.	DESCRIPTION	NOTES
4	ALL	1	W	1789547	SEAL, OIL FEED (2/65-3/68)	NOTE 2
4	ALL	1	W	1426698	SEAL, OIL FEED (3/68-UP)	NOTE 2
5	ALL	1	F	116388-ES	DOWEL, .516" DIA.	
6	ALL	1	F	1790651	DOWEL, .392" DIA.	
7	ALL	1	F	6113977	HOUSING, TIMING GEAR	
7A	ALL	1	F	1789541	PLUG, CUP TYPE, 3/8"	
*	ALL	6	L	0E303-C	BOLT, 3/8-16 x 1 1/4	
*	ALL	1	F	1715827	BOLT, 3/8-16 x 7/8	
*	ALL	7	L	0C41	LOCKWASHER, 3/8	
8	ALL	1	F	6059086	GASKET, TIMING GEAR HOUSING	
9	ALL	1	F	1582837	COVER, TIMING GEAR HSG.	
10	ALL	1	F	6062635	SEAL, FRONT OIL	
11	ALL	1	F	1789834	GASKET, HSG. TO BLOCK	
12	ALL	2	F	1789945	BOLT, HSG. TO BRG. CAP	
13	ALL	18	L	0C31	LOCKWASHER, 5/16"	
14	ALL	18	F	1583040	BOLT, 5/16-18 x 1/2	
15	EF	4/6	F	1787897	LINER, CYLINDER	
15	I	6	F	1526012	LINER, CYLINDER, GRADE 1	NOTE 1
15	I	6	F	1526010	LINER, CYLINDER, GRADE 2	NOTE 1
16	ALL	2	F	1401461	STUD, TIMING GEAR HSG.	
17	ALL	1	F	1789436	GASKET, FUEL PUMP	
18	ALL	1	L	2D29	GASKET, OIL TAKE-OFF	
*	ALL	1	F	1703827	PETCOCK, BLOCK DRAIN (SPIGOT TYPE)	
*	ALL	1	L	3J2	PETCOCK, BLOCK DRAIN (TEE HANDLE TYPE)	
*	ALL	2/4	F	1716356	PLUG, EXPANSION, 1.672"	
*	ALL	AR	F	6048527	PLUG, EXPANSION, 2 7/32"	
*	ALL	AR	F	1761991	PLUG, REAR, 2 13/64"	
*	ALL	AR	F	1561836	PLUG, TACH. TAKE-OFF, 1 1/16"	
*	ALL	1	F	1788927	PLUG, OIL GALLERY, .594"	
19		1	F	1702961	TIMING MARKER (NOT USED ON ALL MODELS)	
70	ALL	AR	F	1788928	PLUG, CAM. BORE 2 21/64"	
70	ALL	AR	F	6048528	PLUG, CAM. BORE, 2.203"	

NOTE 1: LINERS AND PISTONS ON TURBO ENGINES ARE MARKED EITHER 1 OR 2 ACCORDING TO CLEARANCE OR FIT BETWEEN BOTTOM SKIRT OF PISTON AND CYLINDER BORE. TOP OF PISTON IS MARKED EITHER 1 OR 2 AND THE BLOCK IS LIKEWISE STAMPED ON PUSH-ROD SIDE OF CYLINDER BLOCK ADJACENT TO THE TOP FACE DURING MANUFACTURE.

NOTE 2: YELLOW IDENTIFICATION MARK ON 1426698 BOTH KEY #4 SEALS INCLUDED IN KEY #3 GASKET KITS.

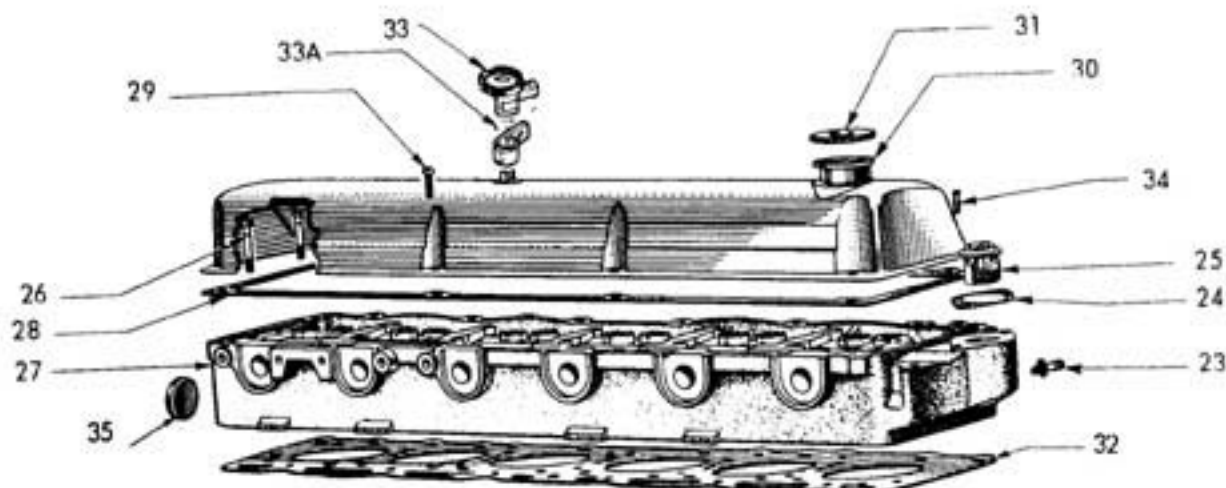

KEY	ENGINE	QUAN	CODE	PART NO.	DESCRIPTION	
23	ALL	4/6	F	6087437	STUD MAINIF. TO HEAD	
24	ALL	1	F	1541317	GASKET, TANK TO CYL. HEAD	
	I	1		6002351	GASKET, THERM. HOUSING	NOTE 2
25	EFGH	1	F	1595156	THERMOSTAT 172°	
25	EFGH	1	F	6071840	THERMOSTAT, 178°	
26	ALL	17/25	F	1415284	BOLT, CYL. HEAD	
26	I	25	F	6071840	BOLT, CYL. HEAD	NOTE 1
27	EG	1	F	6100889	HEAD, CYL.	
27	FH	1	F	1599146	HEAD, CYL.	
27	I	1	F	1599147	HEAD, CYL.	
28	EG	1	F	1762246	GASKET, ROCKER COVER	
28	FHI	1	F	1762293	GASKET, ROCKER COVER	
29	ALL	7/8	F	1568855	SCREW, ROCKER COVER	
30	EG	1	F	6090236	COVER, ROCKER COVER	
30	FHI	1	F	6090237	COVER, ROCKER COVER	
31	ALL	1	F	6071651	CAP, OIL FILL	
32	F	1	F	1564186	GASKET, CYL. HEAD	SEE ALSO KEY 3
32	EG	1	F	1564187	GASKET, CYL. HEAD	SEE ALSO KEY 3
32	HI	1	F	1574857	GASKET, CYL. HEAD	SEE ALSO KEY 3

33	ALL	1	F	1548074	EMISSION VALVE	
33-A	ALL	1	F	1408907	CLAMP, EMISSION VALVE	
34	ALL	2	L	0D10	STUD, TANK MOUNTING	
*	ALL	2	L	0C31	LOCKWASHER, 5/16"	
*	ALL	2	L	0B25	NUT, 5/16-24	
35	ALL	1	F	1716356	PLUG, CYL. HEAD, REAR, 1.672"	

NOTE 1: BOLT WITH INTEGRAL WASHER, NOT INTERCHANGEABLE WITH OTHER TYPE BOLTS.  
 NOTE 2: MUST BE USED WITH THERMOSTAT HOUSING PART #752

## CRANKSHAFT, CAMSHAFT, PISTONS, RINGS AND BEARINGS

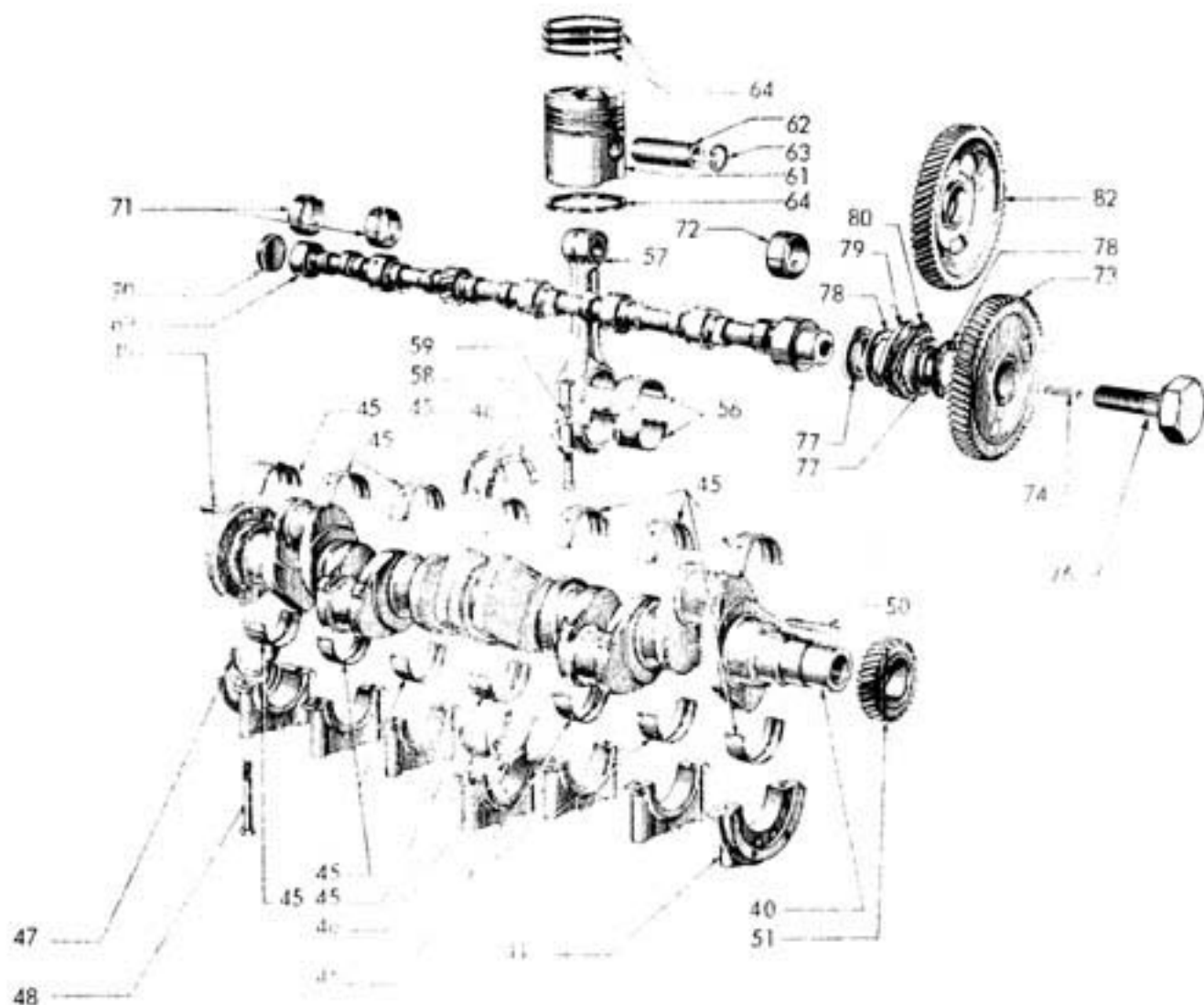

KEY	ENGINE	QUAN	CODE	PART NO.	DESCRIPTION	
40	EG	1	F	6106523	CRANKSHAFT	
40	FH	1	F	1515814	CRANKSHAFT	
40	I	1	F	1512271	CRANKSHAFT	
41	ALL	1	F	1754741	BEARING CAP, FRONT MAIN	
45	EG	1	F	1582109	KIT, MAIN BRG. STD ID, STD OD	NOTE 2
45	EG	1	F	1473045	KIT, MAIN BRG. .010 U/S ID STD OD	NOTE 2
45	EG	1	F	1473046	KIT, MAIN BRG. .020 U/S STD OD	NOTE 2
45	EG	1	F	1473047	KIT, MAIN BRG. .030 U/S ID STD OD	NOTE 2
45	EG	1	F	1473016	KIT, MAIN BRG. .040 U/S ID STD OD	NOTE 2
45	FHI	1	F	1582109	KIT, MAIN BRG. STD ID STD OD	NOTE 2
45	FHI	1	F	1473041	KIT, MAIN BRG. .010 U/S ID STD OD	NOTE 2
45	FHI	1	F	1473042	KIT, MAIN BRG. .020 U/S ID STD OD	NOTE 2
45	FHI	1	F	1473040	KIT, MAIN BRG. .030 U/S ID STD OD	NOTE 2
45	FHI	1	F	1473039	KIT, MAIN BRG. .040 U/S ID STD OD	NOTE 2

KEY	ENGINE	QUAN	CODE	PART NO.	DESCRIPTION	
46	ALL	2	F	1728432	KIT, THRUST WASHER, STD	NOTE 3
46	ALL	2	F	1728433	KIT, THRUST WASHER, .0025 O/S	NOTE 3
46	ALL	2	F	1728434	KIT, THRUST WASHER, .005" O/S	NOTE 3
46	ALL	2	F	1728435	KIT, THRUST WASHER, .0075" O/S	NOTE 3
46	ALL	2	F	1728436	KIT, THRUST WASHER, .010" O/S	NOTE 3
46	ALL	2	F	1728437	KIT, THRUST WASHER, .015" O/S	NOTE 3
46	ALL	2	F	1728438	KIT, THRUST WASHER, .020" O/S	NOTE 3
47	ALL	2	F	6105490	SEAL, CRANKSHAFT OIL	
48	ALL	10/14	F	1788352	BOLT, BRG. CAP	
49	ALL	1	F	1710714	DOWEL, CRANKSHAFT	
50	ALL	1	F	1512311	KEY, CRANKSHAFT GEAR	
51	ALL	1	F	1487748	GEAR, CRANKSHAFT	
56	EFGH	8/12	F	1428375	BEARING, CONN ROD, STD.	
56	EFGH	8/12	F	1428376	BEARING, CONN ID, .010 U/S	
56	EFGH	8/12	F	1428377	BEARING, CONN ID, .020 U/S	
56	EFGH	8/12	F	1428378	BEARING, CONN ID, .030 U/S	
56	EFGH	8/12	F	1428379	BEARING, CONN ID, .040 U/S	
56	I	6	F	1537592	BEARING, CONN. ROD STD UPPER	
56	I	6	F	1537556	BEARING, CONN. ROD .010" UPPER	
56	I	6	F	1537557	BEARING, CONN. ROD .020" UPPER	
56	I	6	F	1428375	BEARING, CONN. ROD STD LOWER	
57	EF	4/6	F	6007061	CONN. ROD ASSY. STD.	
57	GH	4/6	F	6007061	CONN. ROD ASSY. STD	
57	GH	4/6	F	6007062	CONN. ROD ASSY. (.003")	NOTE 4
57	GH	4/6	F	6007063	CONN. ROD ASSY. (.006")	NOTE 4
57	GH	4/6	F	6007064	CONN. ROD ASSY. (.009")	NOTE 4
57	I	6	F	6088942	CONN. ROD ASSY. STD	
57	I	6	F	1542956	CONN. ROD ASSY. (.003")	NOTE 4
58	ALL	8/12	F	1447624	BOLT, CONN. ROD	
59	ALL	8/12	F	1428387	PIN, TENSION	
60	EF	4/6	F	1710453	BUSHING, CONN. ROD	
60	GHI	4/6	F	1497464	BUSHING, CONN. ROD	

NOTE 2 - EACH KIT CONTAINS FULL SET OF MAIN BEARINGS FOR LISTED ENGINE.  
NOTE 3 - EACH KIT CONTAINS 2 HALF WASHERS (EACH ENGINE REQUIRES 2 KITS).  
NOTE 4 - DIMENSION INDICATES PISTON HEIGHT ABOVE BLOCK SURFACE.



KEY	ENGINE	QUAN	CODE	PART NO.	DESCRIPTION	NOTES
61	EF	4/6	F	1436363	PISTON, PIN & RINGS STD.	
61	GH	4/6	F	1587878	PISTON, PIN & RINGS, STD.	
61	GH	4/6	F	1587879	PISTON, PIN & RINGS, .015" o/s	NOTE 3
61	GH	4/6	F	1587880	PISTON, PIN & RINGS, .035" o/s	NOTE 3
61	GH	4/6	F	1587881	PISTON, PIN & RINGS, .055" o/s	NOTE 3
61	I	6	F	1523643	PISTON, PIN & RINGS, STD	
62	EF	4/6	F	1516961	PIN, PISTON	
62	GHI	4/6	F	1516960	PIN, PISTON	
63	EF	8/12	F	1710376	RETAINER, PISTON PIN	
63	GHI	8/12	F	1415288	RETAINER, PISTON PIN	
64	EF	2/3	F	1584935	KIT, PISTON RING, STD	NOTE 2
64	EF	2/3	F	1719953	KIT, PISTON RING, .025" o/s	NOTE 2
64	GH	4/6	F	1584931	KIT, PISTON RING, STD	
64	GH	4/6	F	1584932	KIT, PISTON RING, .015" o/s	
64	GH	4/6	F	1584933	KIT, PISTON RING, .035" o/s	
64	GH	4/6	F	1584934	KIT, PISTON RING, .055" o/s	
64	I	3	F	1548729	KIT, PISTON RING, STD. (1/73/UP)	NOTE 2
69	EG	1	F	1587825	CAMSHAFT	NOTE 1
69	FHI	1	F	1487978	CAMSHAFT	
70	ALL	1	F	1788928	PLUG, CAMSHAFT, REAR	
71	ALL	3/5	F	1789333	BRG., CAMSHT, EXCEPT FRONT, STD.	
71	ALL	3/5	F	1789334	BRG., CAMSHT, EXCEPT FRONT, .020" o/s OD	
72	ALL	1	F	1794742	BRG., CAMSHT, FRONT, STD.	
72	ALL	1	F	1794743	BRG., CAMSHT, FRONT, .020 o/s OD	
73	ALL	1	F	1599143	GEAR, CAMSHAFT (COLOR CODE BLUE)	
74	ALL	1	F	1789748	KEY, CAM GEAR	
76	ALL	1	F	1487140	BOLT, CAM GEAR	NOTE 4
77	EF	1	F	N.L.A.	COLLAR, CAMSHT, THRUST (CHAMFERED)	
77	ALL	1	F	1427085	COLLAR, CAMSHT, THRUST (PLAIN)	
78	ALL	2	F	1793898	WASHER, CAMSHT THRUST	
79	ALL	1	F	1701616	PLATE, CAMSHT THRUST	

NOTE 1 - WHEN USED IN CYLINDER BLOCK CONTAINING CAMSHAFT LINERS, THE PHOSPHATE COATING MUST BE REMOVED FROM BEARING JOURNALS.

NOTE 2- THESE PISTON RING KITS CONTAIN SUFFICIENT RINGS FOR TWO PISTONS.

NOTE 3 - REPLACE IN COMPLETE ENGINE SETS. BORE SIZES MAY NOT BE MIXED.

NOTE 4 - FORMERLY SEPARATE BOLT & WASHER



KEY	ENGINE	QUAN	CODE	PART NO.	DESCRIPTION	NOTES
80	ALL	1	F	1702841	PLATE, LOCKING	
*	ALL	3	L	0E303C	BOLT, CAMSHT. THRUST	
82	ALL	1	F	1568733	GEAR, INJ. PUMP DRIVE	
*	ALL	1	F	1515457	NUT, GEAR TO SHAFT	
*	ALL	1	L	0C61	WASHER	
*	ALL	1	F	3416018	KEY	
82	F	1	F	1703843	GEAR, INJ. PUMP. USE WITH C.A.V. (ROTARY) PUMP ONLY	
*	F	3	F	3414943	BOLT, GEAR TO PUMP HUB	
*	F	3	F	3415320	LOCKWASHER	
*	F	1	F	1788818	PIN	

## FLYWHEEL ASSEMBLY

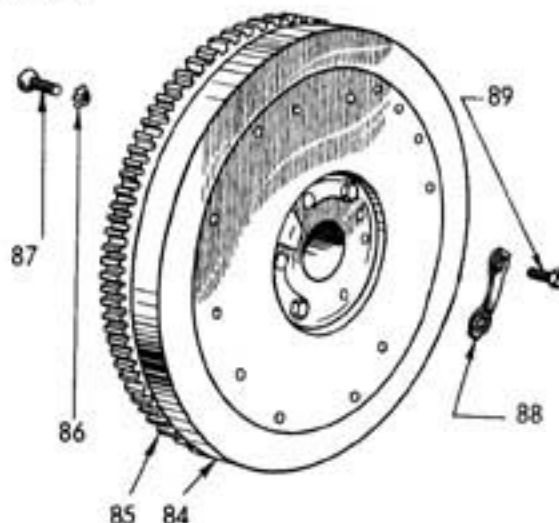
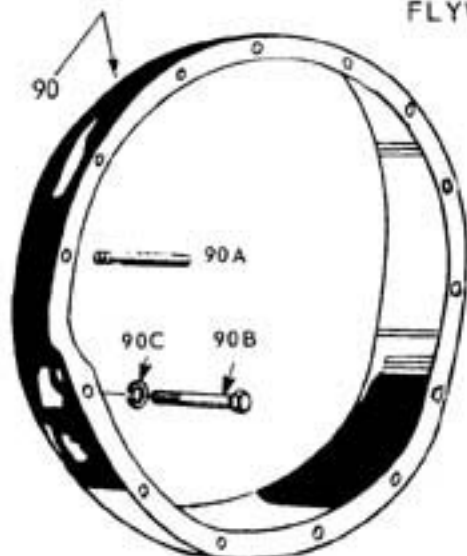

KEY	ENGINE	QUAN	CODE	PART NO.	DESCRIPTION
84	ALL	1	F	1476012	FLYWHEEL ASSY. (INCL. KEY 85)
84	ALL	1	F	1745236	FLYWHEEL ASSY. - SPECIAL 200 LB.
85	ALL	1	F	1710704	RING GEAR, FLYWHEEL
86	ALL	6	F	1606427	LOCKWASHER, RING GEAR
87	ALL	6	F	1758355	SCREW, RING GEAR
88	ALL	3	F	1798064	LOCKPLATE, FLYWHEEL
89	ALL	6	F	1788021	BOLT, FLYWHEEL
90	ALL	1	L	1A373	SPACER, HOUSING (733) (REQ. WITH 200 LB. FLYWHEEL)
90A	ALL	2	L	2K207	DOWEL, SPACER HOUSING
90B	ALL	15	L	0E410	BOLT, 7/16-14 x 4"
90C	ALL	15	L	0C51	LOCKWASHER, 7/16"

## VALVE OPERATING MECHANISM

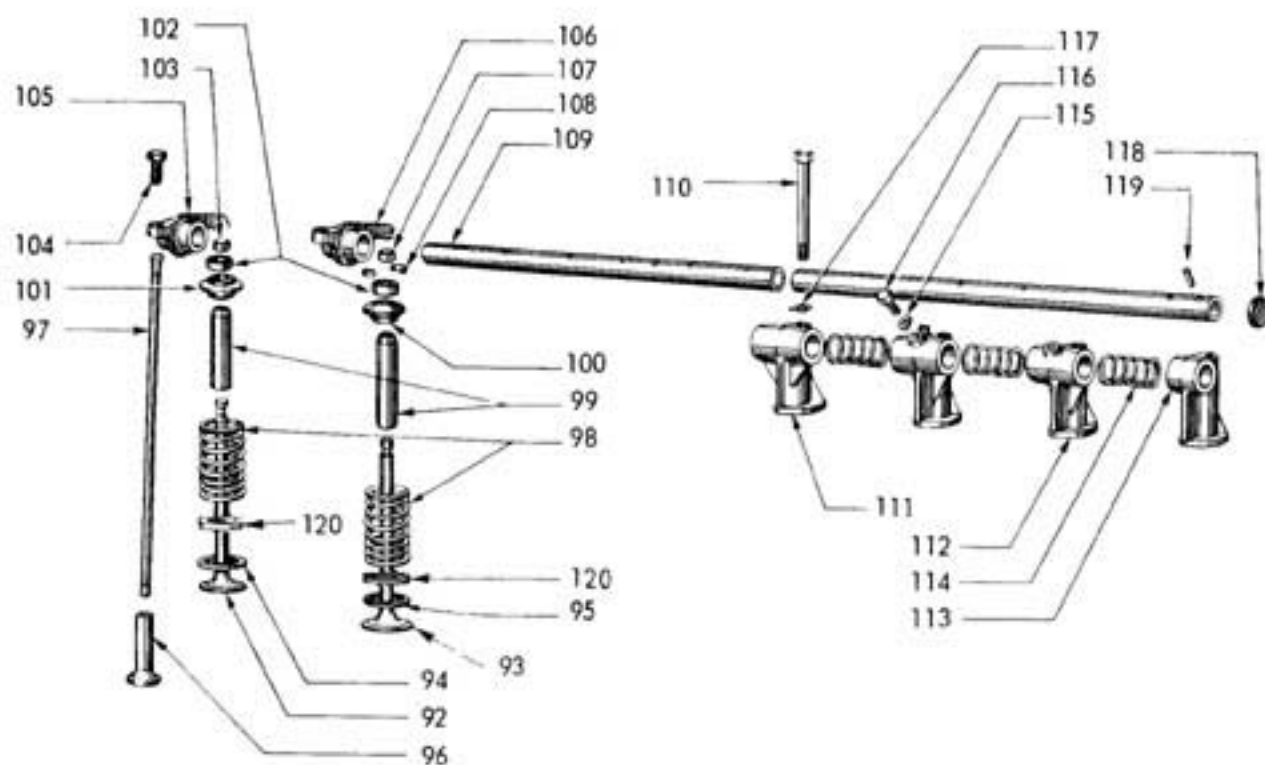

KEY	ENGINE	QUAN	CODE	PART NO.	DESCRIPTION	
92	ALL	4/6	F	1596817	VALVE, EXHAUST	NOTE 3
93	ALL	6	F	1538374	VALVE, INLET	
94	ALL	4/6	F	1710305	INSERT, EXHAUST SEAT, STD.	NOTE 1
94	ALL	4/6	F	1743925	INSERT, EXHAUST SEAT .010" O/S OD	NOTE 1
94	ALL	6	F	1430249	INSERT, EXHAUST SEAT, STD.	NOTE 2
94	ALL	6	F	1430250	INSERT, EXHAUST SEAT, .010" O/S OD	NOTE 2
95	ALL	4/6	F	1788847	INSERT, INTAKE SEAT, STD.	NOTE 1
95	ALL	4/6	F	1788848	INSERT, INTAKE SEAT, .010" O/S OD	NOTE 1
95	ALL	6	F	1430247	INSERT, INTAKE SEAT, STD.	NOTE 2
95	ALL	6	F	1430248	INSERT, INTAKE SEAT, .010" O/S OD	NOTE 2
96	ALL	8/12	F	1403429	TAPPET (STD.)	
97	ALL	8/12	F	1745354	PUSH ROD	
98	ALL	8/12	F	1717773	VALVE SPRING	
99	ALL	8/12	F	1710777	VALVE GUIDE	

NOTE 1: USED THRU ENGINE SERIAL 929496 (JULY 1974)

NOTE 2: USED FROM ENGINE SERIAL 929497 (AUGUST 1974)

NOTE 3: VALVE STEM HAS 1/8" CHAMFERED SLOT. USED WITH (KEY 108) 1596819 TAPERED TYPE COLLET. SERVICE STARTED OCTOBER 1974, REPLACING VALVE 1745444 HAVING SQUARE TYPE SLOT IN STEM.

KEY	ENGINE	QUAN	CODE	PART NO.	DESCRIPTION
100	ALL	4/6	F	1473015	RETAINER, INLET VALVE SPRING
101	ALL	4/6	F	1473015	RETAINER, EXHAUST VALVE SPRING
102	ALL	8/12	F	1710835	SEAL, VALVE STEM
103	ALL	4/6	F	1789727	CAP, EXHAUST VALVE STEM
104	ALL	8/12	F	1789505	SCREW, ROCKER ARM ADJUST.
105	EF	4/6	F	6084185	ROCKER ARM, L.H.
105	GHI	4/6	F	6093620	ROCKER ARM, L.H.
106	EF	4/6	F	6084186	ROCKER ARM, R.H.
106	GHI	4/6	F	6084186	ROCKER ARM, R.H.
107	ALL	4/6	F	1789727	CAP, INTAKE VALVE STEM
108	ALL	8/12	F	1745444	COLLET, SPRING RETAINER, TAPERED TYPE
109	EG	1	F	1788868	SHAFT, ROCKER ARM
109	FHI	2	F	6085961	SHAFT, ROCKER ARM
110	ALL	5/7	F	1716046	BOLT, ROCKER SUPPORT 3/8-16 x 3 1/2"
111	ALL	1	F	1710727	BRACKET, SHAFT SUPP. CENTER
112	ALL	2/4	F	1710726	BRACKET, SHAFT SUPP. INTERMEDIATE
113	ALL	2	F	1710818	BRACKET, SHAFT SUPP., FRONT & REAR
114	ALL	4/6	F	1745333	SPRING, ROCKER ARM LOCATING
115	ALL	2/4	L	0C21	LOCKWASHER
116	ALL	2/4	F	1602472	BOLT
117	ALL	5/7	L	0C41	LOCKWASHER
118	ALL	2	F	3416839	PLUG, ROCKER SHAFT END
119	ALL	2	F	1745347	PIN, ROCKER SHAFT RETAINING. (USE WHEN RQD ONLY)
120	ALL	8/12	F	1789728	SPACER, VALVE SPRING

NOTE 1: USED THRU OCTOBER 1974 WITH EXHAUST VALVE HAVING SQUARE TYPE SLOT IN STEM.

## OIL PUMP ASSEMBLY

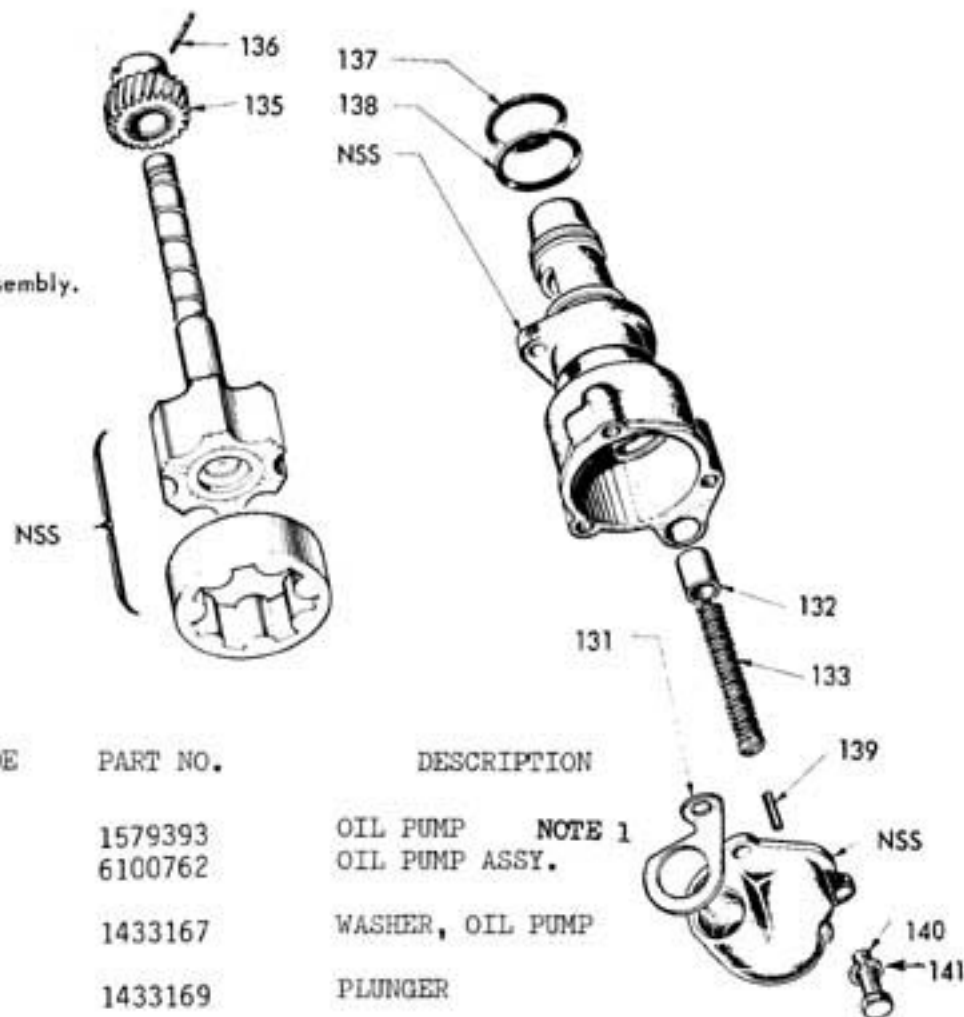

KEY No. 130 - Complete pump assembly.  
NSS - Not supplied separately.

KEY	ENGINE	QUAN	CODE	PART NO.	DESCRIPTION
130	EG	1	F	1579393	OIL PUMP NOTE 1
130	FHI	1	F	6100762	OIL PUMP ASSY.
131	ALL	1	F	1433167	WASHER, OIL PUMP
132	ALL	1	F	1433169	PLUNGER
133	ALL	1	F	1433168	SPRING
135	ALL	1	F	1793868	GEAR, OIL PUMP
136	ALL	1	F	1720056	PIN, GEAR TO SHAFT
137	AR	1	F	1433203	SEAL, 1 7/16" ID
138	AR	1	F	1433204	SEAL, 1 9/16" ID
139	I	1	F	1433211	PIN, COVER TO BODY
140	ALL	3	L	0E202-C	BOLT, OIL PUMP COVER, 5/16 x 1 USS
141	ALL	3	L	0C31	LOCKWASHER, 5/16"
*	ALL	2	L	0E202-C	BOLT, OIL PUMP TO BLOCK, 5/16 x 1 USS
*	ALL	2	L	0C31	LOCKWASHER FOR ABOVE, 5/16"

NOTE 1: MOTOFIDES AND EATON HOLBOURN PUMPS ARE INTERCHANGEABLE.

4 CYLINDER MODELS

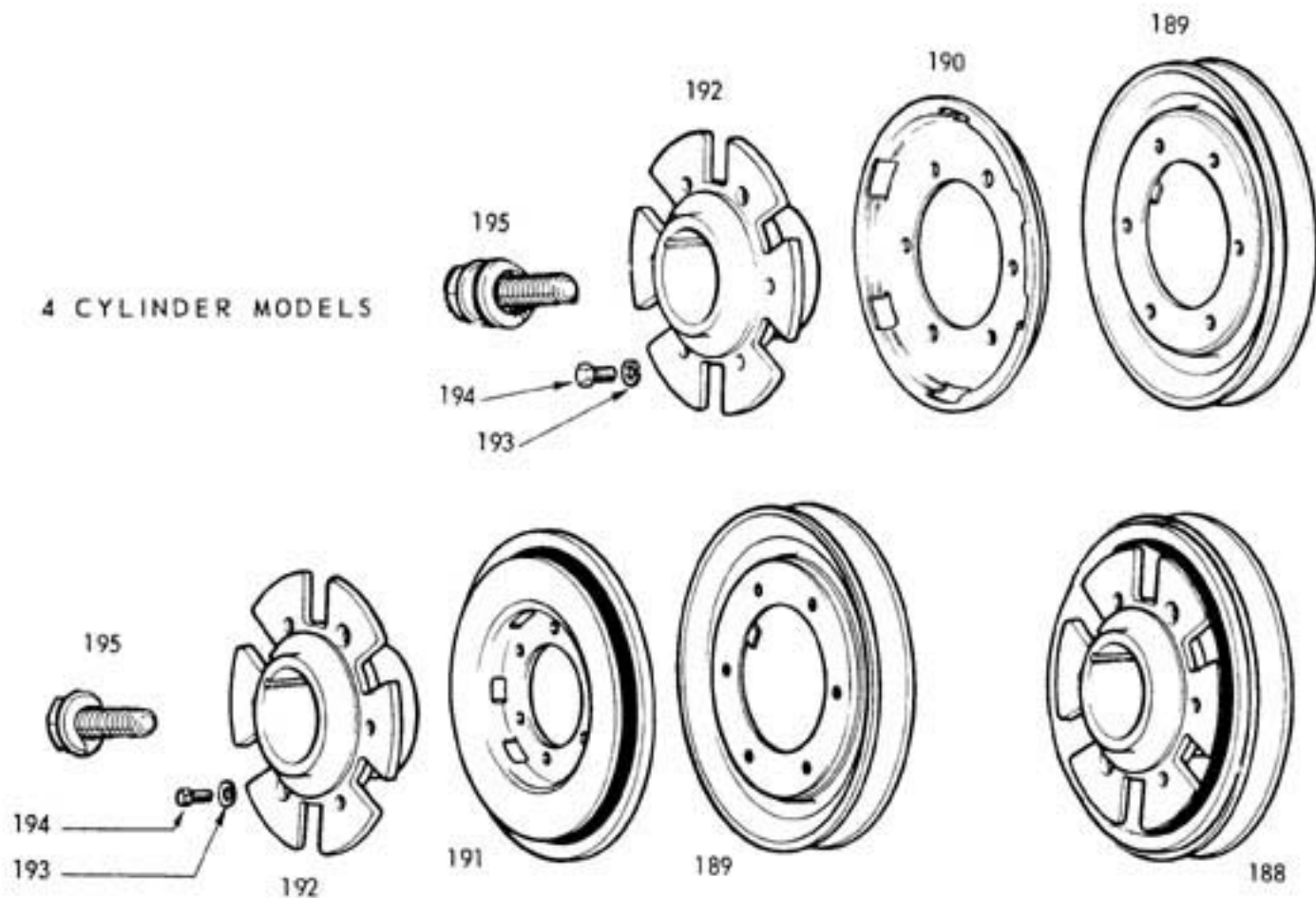

6 CYLINDER MODELS

KEY	ENGINE	QUAN	CODE	PART NO.	DESCRIPTION	
188	HI	1	F	6086403	PULLEY/DAMPER ASSY. 7 5/8" DIA. SINGLE SHEAVE	NOTE 1
	HI	1	F	1549849	PULLEY/DAMPER ASSY. 7 5/8" DIA. DUAL SHEAVE	NOTE 1
189	EFGH	1	F	6086402	PULLEY, CRANKSHAFT	
190	EG	1	F	1778344	PLATE, ENGINE BARRING	
*	ALL	2	F	1794303	DOWEL, BARRING PLATE OR DAMPER TO PULLEY HUB	
191	F	1	F	1794021	DAMPER, CRANKSHAFT, 9 3/4" DIA.	
191	H	1	F	1461766	DAMPER, CRANKSHAFT (THRU 1974), 10 5/8" DIA.	
192	EFGH	1	F	1447271	HUB, CRANKSHAFT PULLEY	
193	EFGH	6	L	0C31	LOCKWASHER	
*	EFGH	2	L	0C30	FLAT WASHER, 5/16"	
194	EFGH	6	F	1715834	BOLT, 5/16-24 x 1"	
195	ALL	1	F	6059090	FLANGED BOLT	

NOTE 1: REPLACES KEY 189 THRU 194 STARTING 1974

## ENGINE SUMP - 6 CYLINDER MODELS

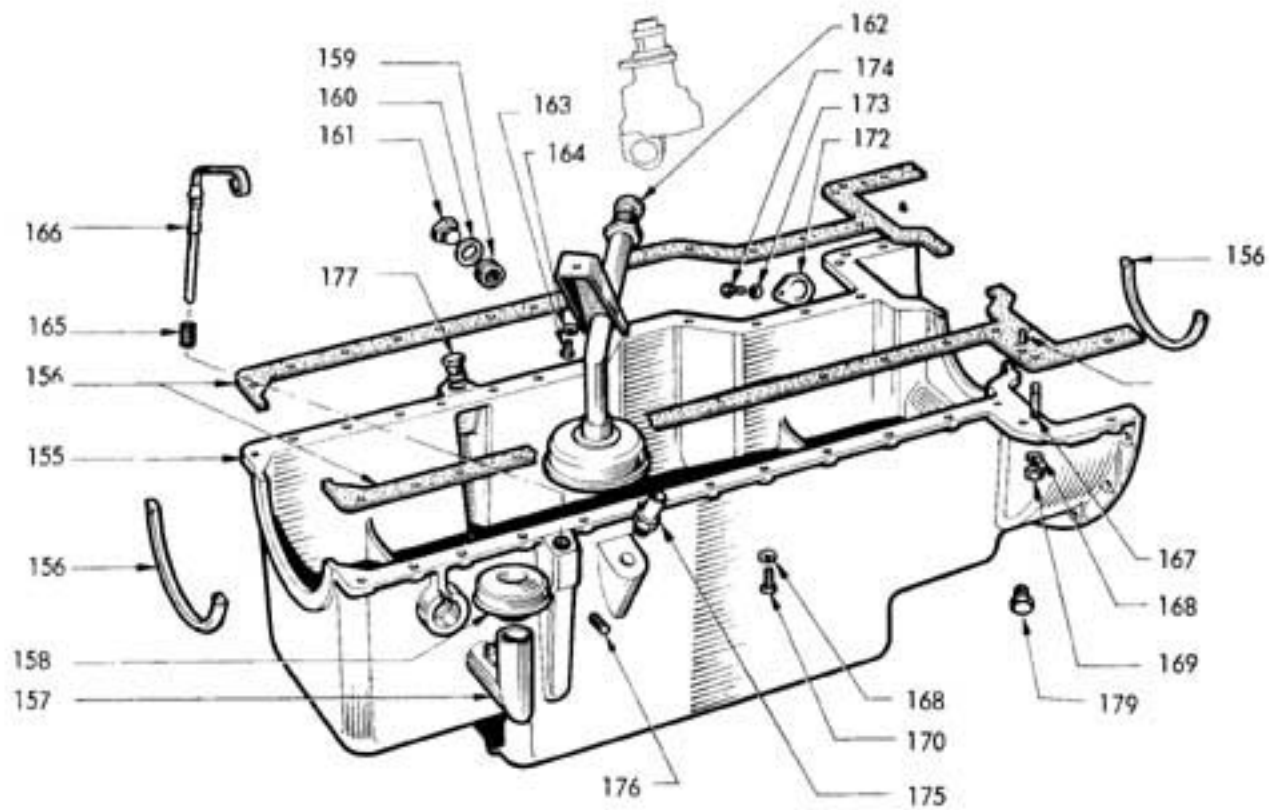

6 CYLINDER FLAT SUMP

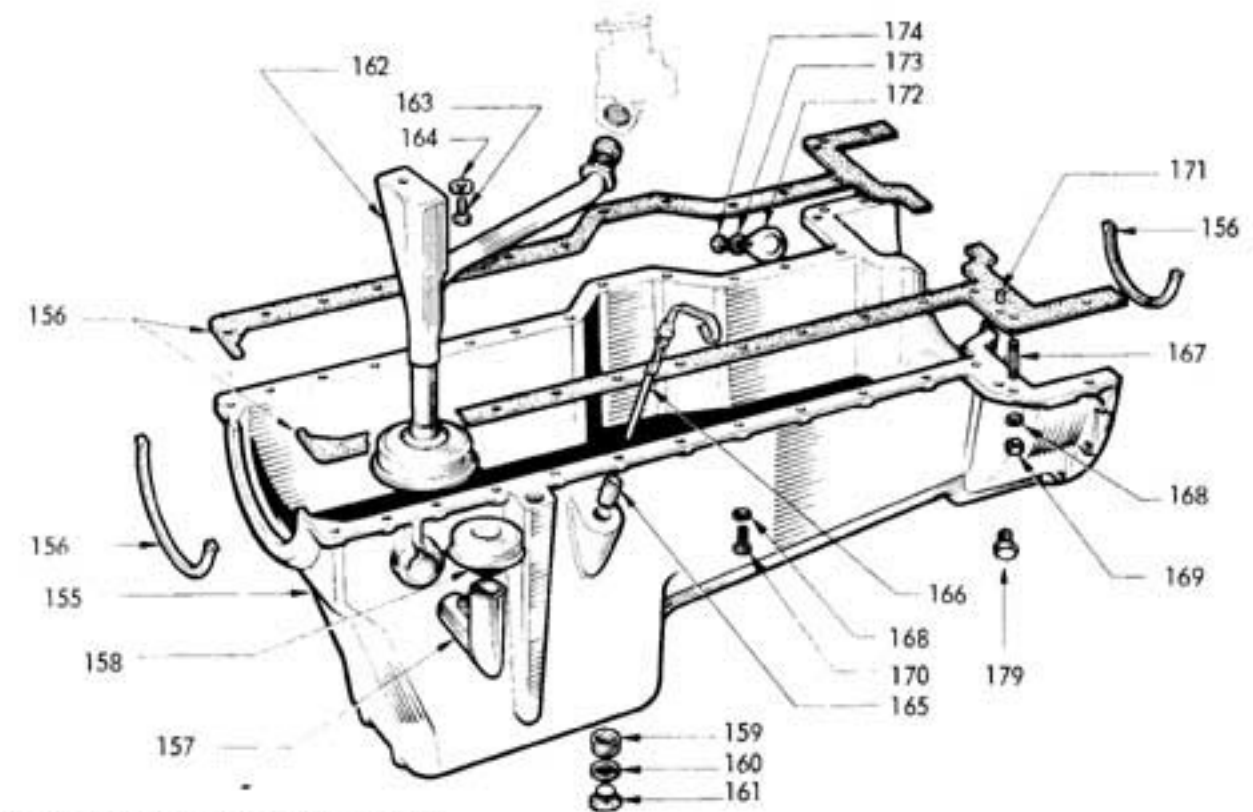

6 CYLINDER FRONT WELL SUMP

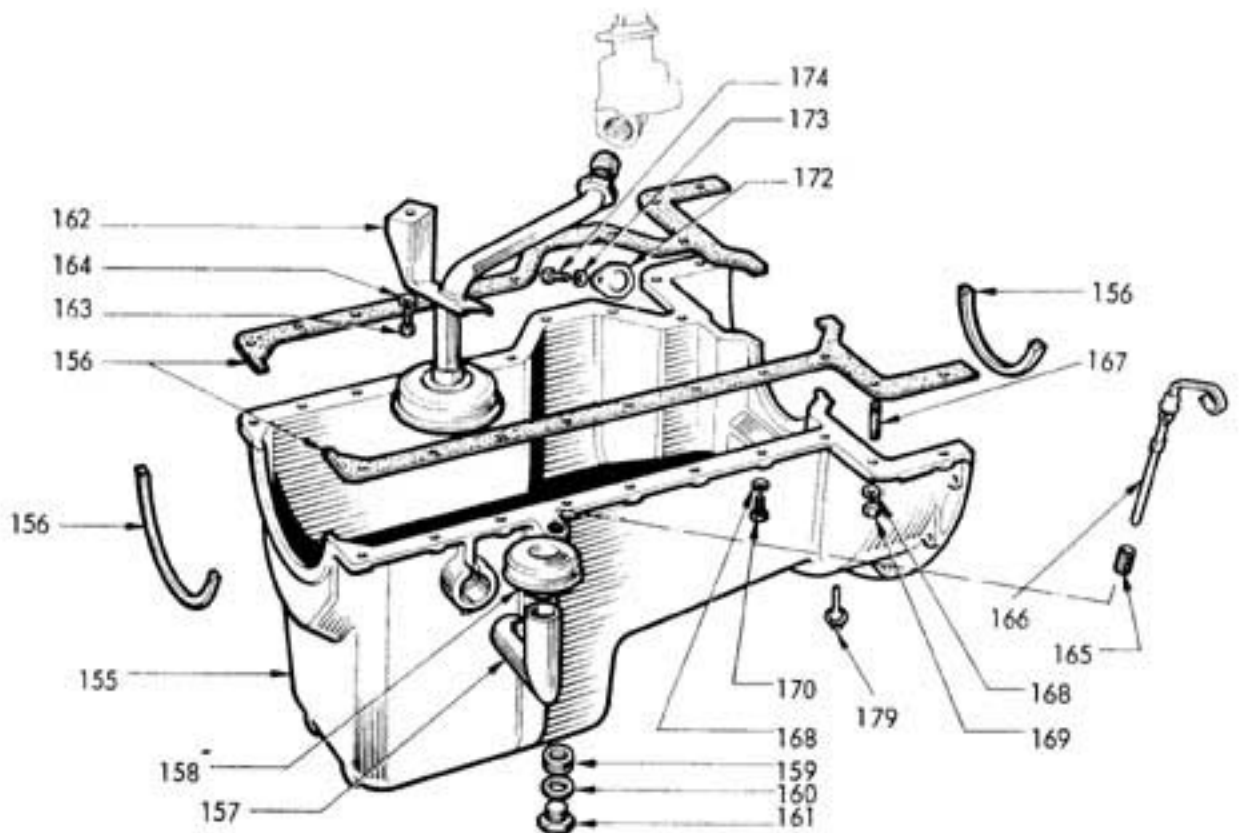
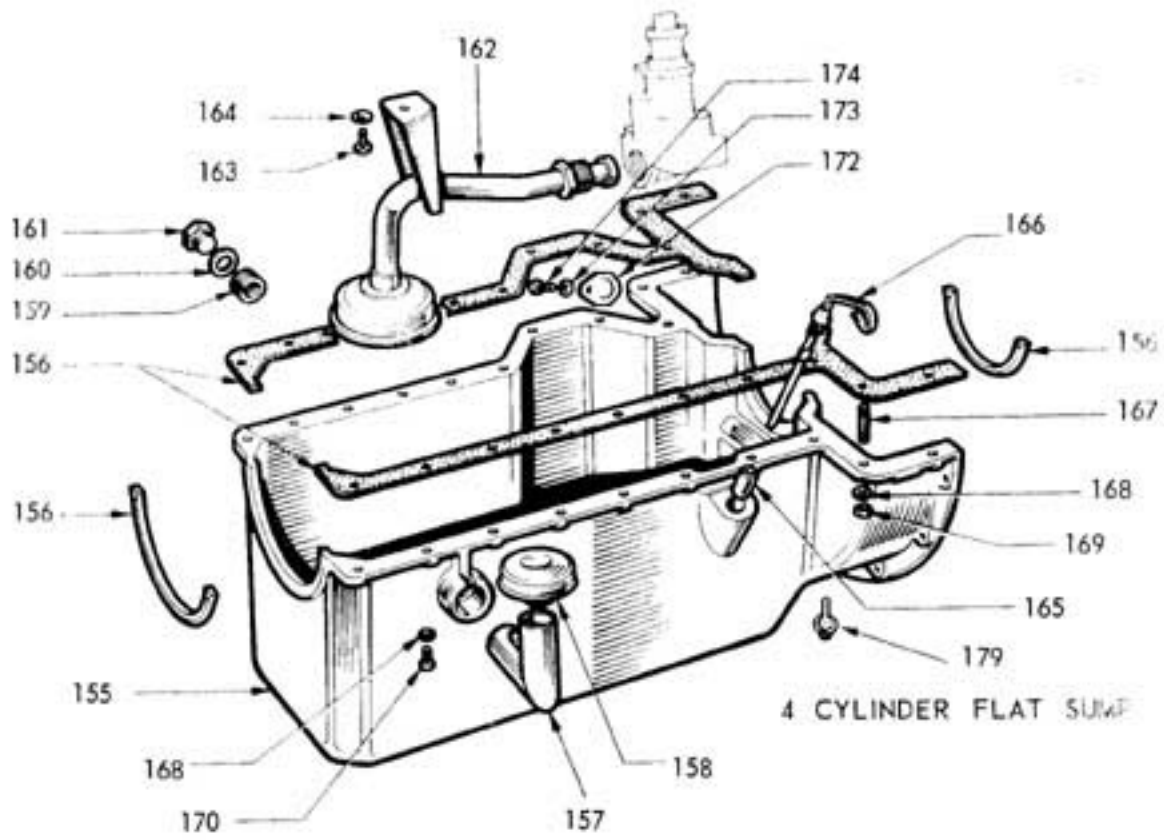

4 CYLINDER FRONT WELL SUMP



KEY	ENGINE	QUAN	CODE	PART NO.	DESCRIPTION
155	EG	1	F	1509694	SUMP, OIL, FLAT TYPE
155	EG	1	F	1789337	SUMP, OIL, FRONT WELL TYPE
155	FH	1	F	1403431	SUMP, OIL, FLAT TYPE
155	FH	1	F	1789337	SUMP, OIL, FRONT WELL TYPE
155	I	1	F	1538997	SUMP, OIL, FLAT TYPE
156	EG	1	F	1428996	KIT, SUMP GASKET
156	FHI	1	F	1428997	KIT, SUMP GASKET
					SEE ALSO KEY #3
					SEE ALSO KEY #3
157	ALL	1	F	1703608	TUBE, CRANKCASE VENT
158	ALL	1	F	1608307	CAP, CRANKCASE VENT
159	ALL	1	F	1708048	INSERT, SUMP DRAIN PLUG
160	ALL	1	F	1710927	GASKET, SUMP DRAIN PLUG
161	ALL	1	F	1704131	PLUG, SUMP DRAIN
162	E	1	F	1797976	TUBE, OIL PICK-UP. USED W/ FRONT WELL SUMP TO ENGINE SERIAL S-647473 (MAR. 1968)
162	EG	1	F	1508085	TUBE, OIL PICK-UP. USED W/FRONT WELL SUMP STARTING ENGINE NO. S-647474.
162	E	1	F	1409810	TUBE, OIL PICK-UP. USED W/FLAT SUMP TO ENGINE SERIAL S-647473 (MAR. 1968)
162	EG	1	F	1508088	TUBE, OIL PICK-UP. USED W/FLAT SUMP STARTING ENGINE SERIAL S-647474
162	FHI	1	F	1508092	TUBE, OIL PICK-UP. USED WITH FLAT SUMP
162	FHI	1	F	1511062	TUBE, OIL PICK-UP. USED WITH FRONT WELL SUMP.
163	ALL	1	F	1583040	BOLT, SUMP TUBE
164	ALL	1	L	0C31	WASHER

KEY	ENGINE	QUAN	CODE	PART NO.	DESCRIPTION
165	EG	1	F	1788795	TUBE, OIL STICK. 3 5/16" OA LONG
165	FH	1	F	1788874	TUBE, OIL STICK. 2 3/8" OA LONG
165	I	1	F	1415303	TUBE, OIL STICK
166	EG	1	F	1791936	DIP STICK, OIL. USED WITH FLAT SUMP
166	FH	1	F	1403432	DIP STICK, OIL. USED WITH FLAT SUMP
166	EFGH	1	F	1710937	DIP STICK, OIL. USED WITH FRONT WELL SUMP.
166	I	1	F	1457366	DIP STICK, OIL.
167	ALL	4	F	6115327	STUD, SUMP TO BLOCK
168	ALL	21/29	L	0C41	LOCKWASHER, 3/8"
169	ALL	4	L	0B34	NUT, 3/8 - 24
170	ALL	21/29	L	0E302	BOLT, 3/8 - 16 x 1"
171	FHI	2	F	1720055	PIN, SUMP TO BLOCK
172	ALL	1	L	1A329	COVER, APERTURE
*	ALL	1	L	1C28	GASKET, APERTURE COVER
173	ALL	1	L	0C31	LOCKWASHER, 5/16"
174	ALL	1	L	0E201	BOLT, 5/16-18 x 1"
175	I	1	F	1433169	ADAPTOR, OIL RETURN
176	I	1	F	1521644	PLUG, SUMP
177	ALL	1	F	1703791	PLUG, OIL STICK TAPPING
179	ALL	1	L	0E290	SELF TAP SCREW/WASHER ASSY.

MANIFOLDS - INTAKE & EXHAUST  
TURBO MODELS ONLY - (For other models see section B)

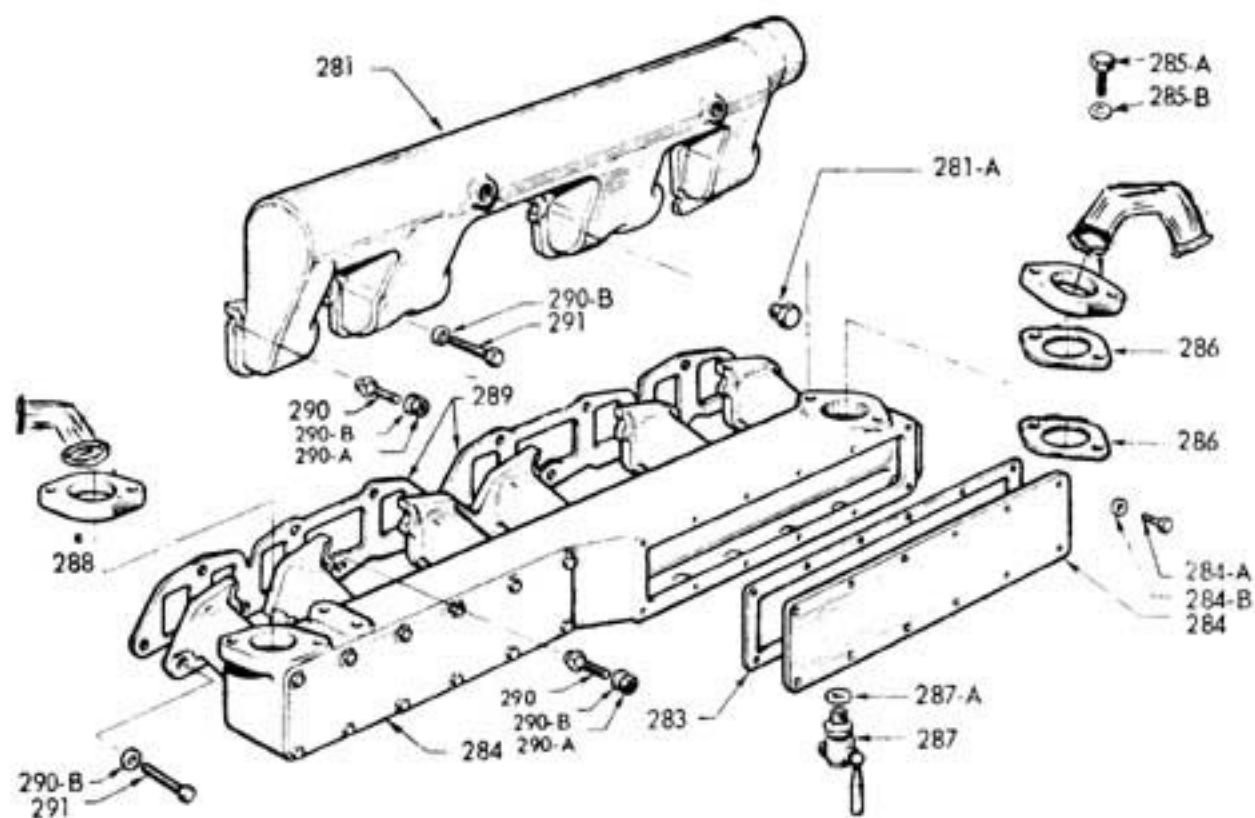

KEY 282 - Complete exhaust manifold ass'y.

KEY	ENGINE	QTY.	COND.	PART NO.	DESCRIPTION
281	I	1	F	6062098	MANIFOLD, INTAKE
281-A	I	2	F	1472481	PLUG, 7/8-14 HEX.
282	I	1	F	1487987	EXHAUST MANIFOLD ASSY., COMPLETE
283	I	2	F	1458318	GASKET, COVER
284	I	2	F	1487988	COVER, WATER JACKET
284-A	I	24	F	1602472	BOLT, COVER, HEX. HD. 1/4-28 x 3/4
284-B	I	24	L	OC-21	LOCKWASHER, 1/4"
285-A	I	4	L	OE-352	BOLT, HEX. HD., 3/8-24 x 1"
285-B	I	4	L	OC-41	LOCKWASHER, 3/8"

KEY	ENGINE	QUAN.	CODE	PART NO.	DESCRIPTION
286	I	2	F	1458319	GASKET, FLANGE
287	ALL	1	F	1703827	PEYCOCK, DRAIN
287-A	I	1	F	1796718	WASHER, COPPER, 1/2" x 3/4" x .064"
288	I	1	F	1A385	ELBOW
289	I	2	F	1418493	GASKET, MANIFOLD TO HEAD
290	ALL	7	F	6087437	STUD
290-A	I	7	L	0B-34	NUT, HEX., 3/8-24
290-B	I	13	F	1415664	WASHER, FLAT, .420" ID x .880" OD
291	I	6	L	0E303-C	BOLT, HEX. HD., 3/8-16 x 1 1/4"
292	I	1	F	1A386	ELBOW

## FUEL INJECTION SYSTEM (TYPICAL)

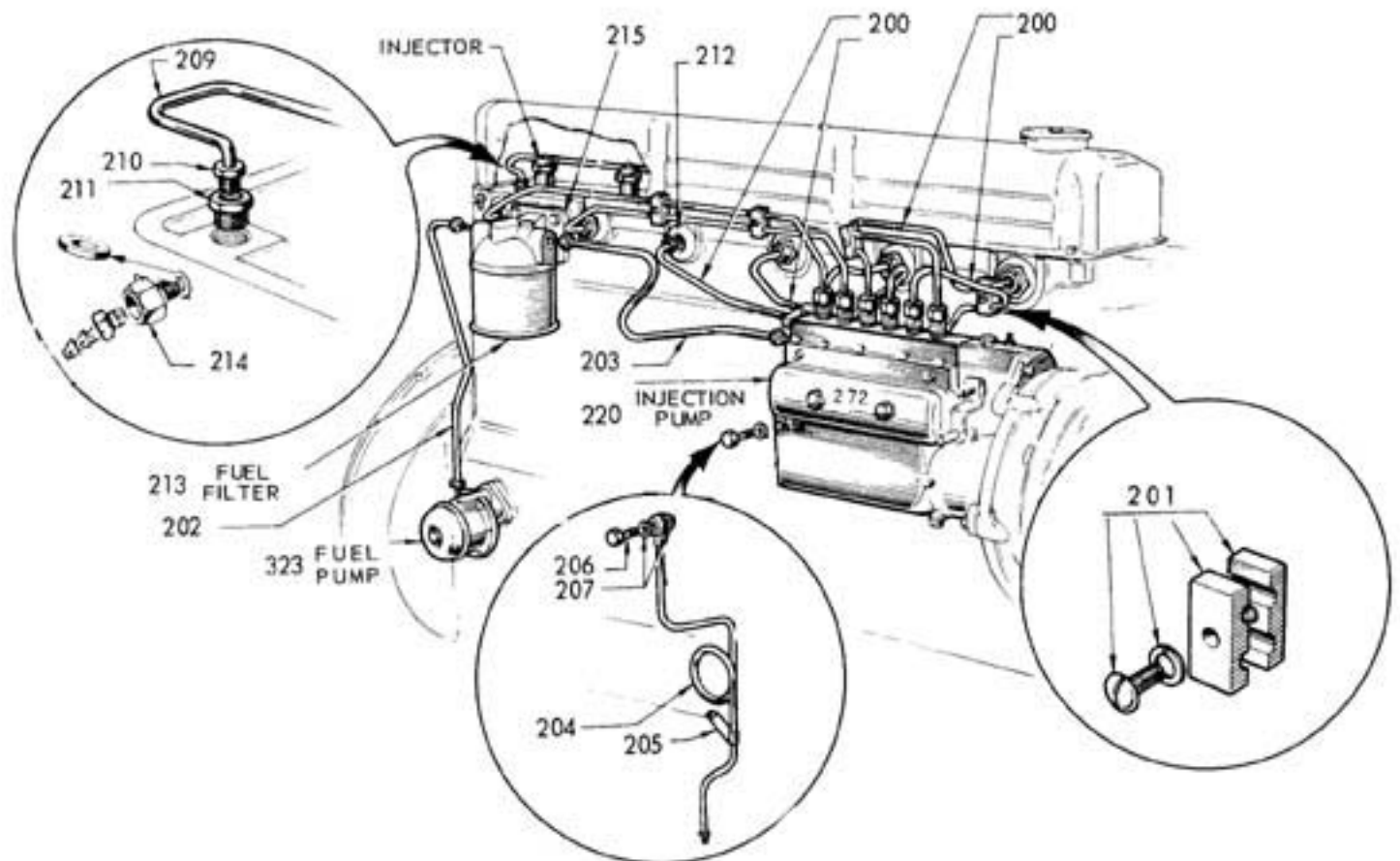

KEY	ENGINE	QUAN	CODE	PART NO.	DESCRIPTION
-----	--------	------	------	----------	-------------

THE FOLLOWING INJECTION PIPES SUIT SIMMS INJECTOR PUMP ONLY:

200	ALL	1	F	1791103	PIPE, INJECTION, No. 1
200	EG	1	F	1791105	PIPE, INJECTION, No. 2
200	FHI	1	F	1791106	PIPE, INJECTION, No. 2
200	EG	1	F	1791108	PIPE, INJECTION, No. 3
200	FHI	1	F	1791111	PIPE, INJECTION, No. 3
200	EG	1	F	1791113	PIPE, INJECTION, No. 4
200	FHI	1	F	1791114	PIPE, INJECTION, No. 4
200	FHI	1	F	1791116	PIPE, INJECTION, No. 5
200	FHI	1	F	1791118	PIPE, INJECTION, No. 6

THE FOLLOWING PIPES SUIT C.A.V. INJECTION PUMPS ONLY:

200	F	1	F	1791104	PIPE, INJECTION, No. 1
200	F	1	F	1791107	PIPE, INJECTION, No. 2
200	F	1	F	1791112	PIPE, INJECTION, No. 3
200	F	1	F	1791115	PIPE, INJECTION, No. 4
200	F	1	F	1411469	PIPE, INJECTION, No. 5
200	F	1	F	1791121	PIPE, INJECTION, No. 6
201	EG	3/6	F	3649	CLIP, INJ. PIPE (2 GROOVES)

KEY	ENGINE	QUAN	CODE	PART NO.	DESCRIPTION
202	E	1	F	1487984	FUEL PIPE
202	G	1	F	9200006	FUEL PIPE, USE WITH SINGLE BOWL FILTER
202	G	1	F	9200006	FUEL PIPE, USE WITH DUAL BOWL FILTER
202	F	1	F	1447315	FUEL PIPE, USE WITH SINGLE BOWL FILTER
202	H	1	F	9200006	FUEL PIPE, USE WITH SINGLE BOWL FILTER
202	H	1	F	9200006	FUEL PIPE, USE WITH DUAL BOWL FILTER
202	I	1	F	1487744	FUEL PIPE
203	EG	1	F	1464561	FUEL PIPE, USE WITH DUAL BOWL FILTER
203	FHI	1	F	1427611	FUEL PIPE, USE WITH DUAL BOWL FILTER
203	FHI	1	F	1489009	FUEL PIPE, USE WITH SINGLE BOWL FILTER
203	F	1	F	1700361	FUEL PIPE, USE WITH C.A.V. INJ. PUMP AND SINGLE BOWL FILTER (FUEL RETURN)
204	EG	1	F	1407447	LEAK-OFF PIPE, INJ. PUMP (NOTE 1)
204	FHI	1	F	6097947	LEAK-OFF PIPE, INJ. PUMP (NOTE 1)
205	ALL	1	F	1461587	CLIP, LEAK-OFF PIPE (NOTE 1)
206	ALL	1	F	1749944	PLUG
206	ALL	1	F	1788796	BOLT, LEAK-OFF (NOTE 1)
207	ALL	1	F	1422409	WASHER
207	ALL	2	F	1422409	WASHER (NOTE 1)
209	EG	1	F	1514296	PIPE, INJECTOR LEAK-OFF
209	FHI	1	F	1514297	PIPE, INJECTOR LEAK-OFF
210	ALL	1	F	1481753	NUT, COMPRESSION - USE WITH E455036-ES STEEL CONNECTOR
210	ALL	1	L	3E12	NUT, COMPRESSION - USE WITH 131404-ES BRASS CONNECTOR
211	ALL	1	F	1514322	CONNECTOR - STEEL
212	ALL	4/6	F	1791096	SEAL
213	ALL	1	F	FUEL FILTER	SEE FOLLOWING PAGES
214	ALL	1	L	3E36	ADAPTOR, LEAK OFF PIPE (NOTE 2)
215	ALL	1	L	1A233	MOUNTING BRACKET FOR SINGLE BOWL FILTER
215	ALL	1	F	1427610	MOUNTING BRACKET FOR DUAL BOWL FILTER
216	ALL	1	F	3C26	HOSE BARB

NOTE 1: LEAK-OFF PIPE (KEY 204) WITH ATTACHING PARTS AND NON-VENTED COVER (KEY 272) USED TO FEBRUARY 1975 ONLY.

NOTE 2: BANJO FITTING USED TO JUNE 1974 CONSISTS OF:

1	F	1714487	BANJO ADAPTOR, LEAK-OFF
1	F	1715904	BOLT, LEAK-OFF
2	F	1707206	WASHER
1	F	3C26	ADAPTOR

(KEY 213) FUEL FILTERS  
 (All part numbers on this page are code F)

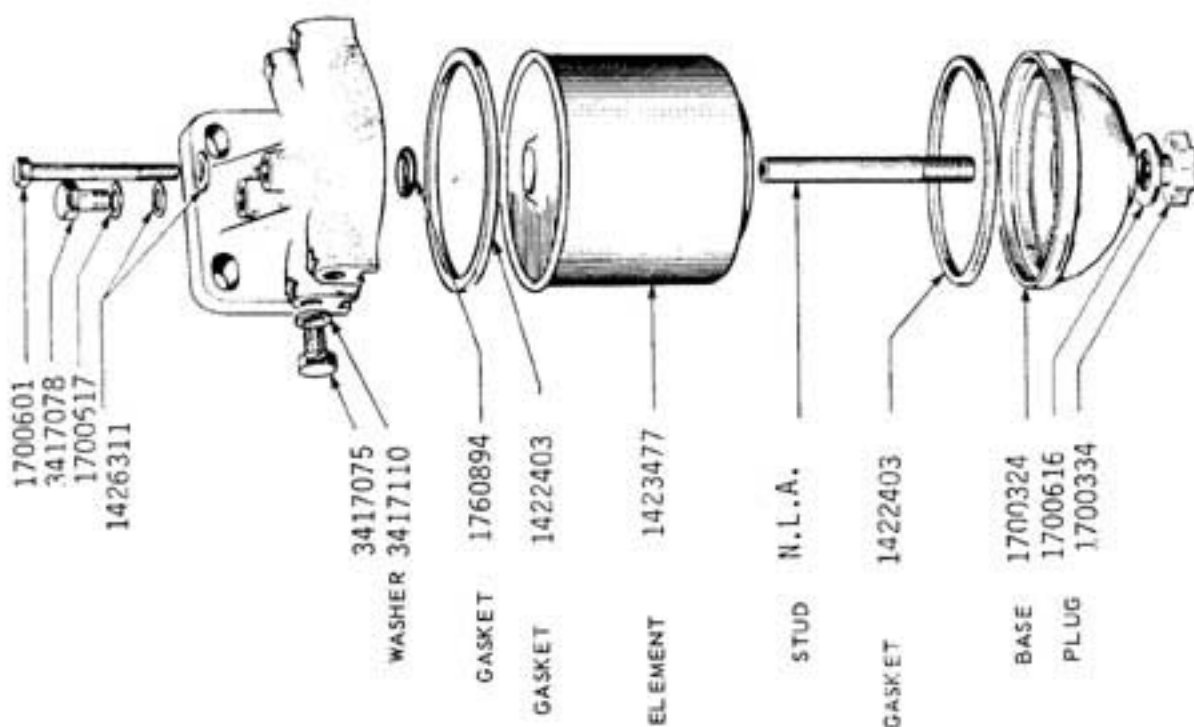

(KEY 213) FUEL FILTER ASSEMBLY FOR "F" ENGINES.  
 C.A.V. SINGLE BOWL TYPE - Identification 583  
 1789434 Complete filter assembly.  
 1423477 Element kit. Includes all items marked E.

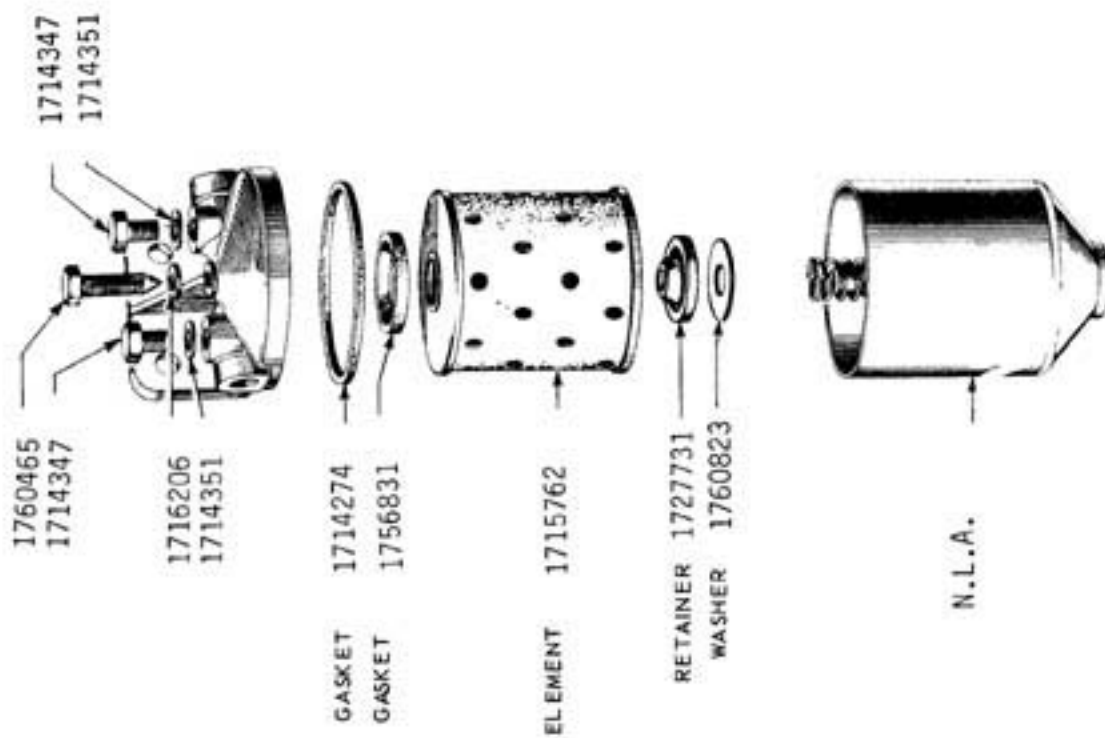

(KEY 213) FUEL FILTER ASSEMBLY FOR "E" ENGINES -  
 A.C. TYPE - Identification DOA-1  
 N.L.A. Complete filter assembly.  
 1715762 Element kit. Includes all items marked E.



(KEY 213) FUEL FILTERS  
 (All part numbers on this page are code F)

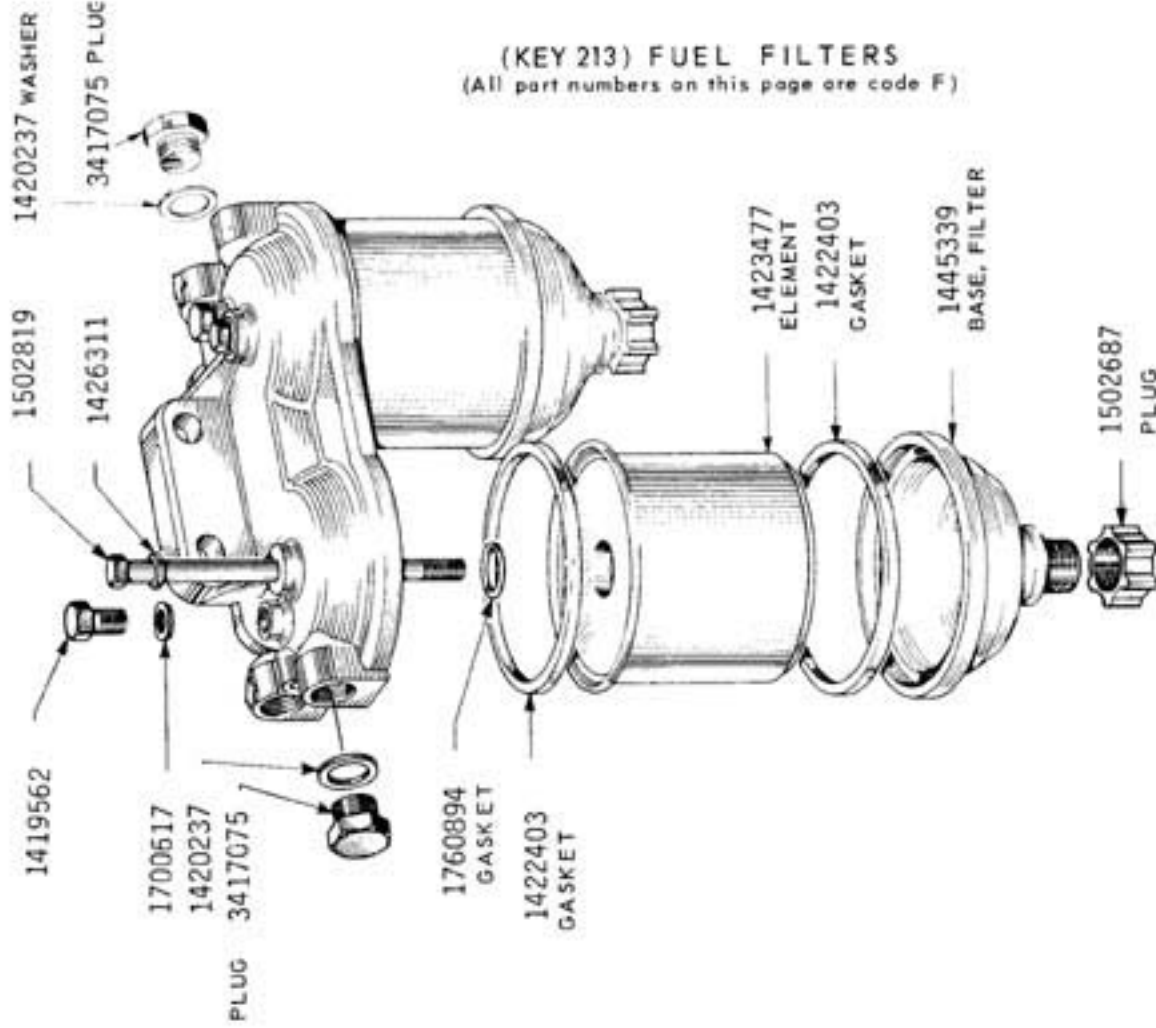

(KEY 213)

FUEL FILTER ASSEMBLY - USED ON ALL ENGINES.  
 SIMMS DOUBLE BOWL TYPE - Identification FH-61 or FH-89

- 6065057 Complete filter assembly.
- 1423477 Element kit. Includes all items marked £. (2 required)

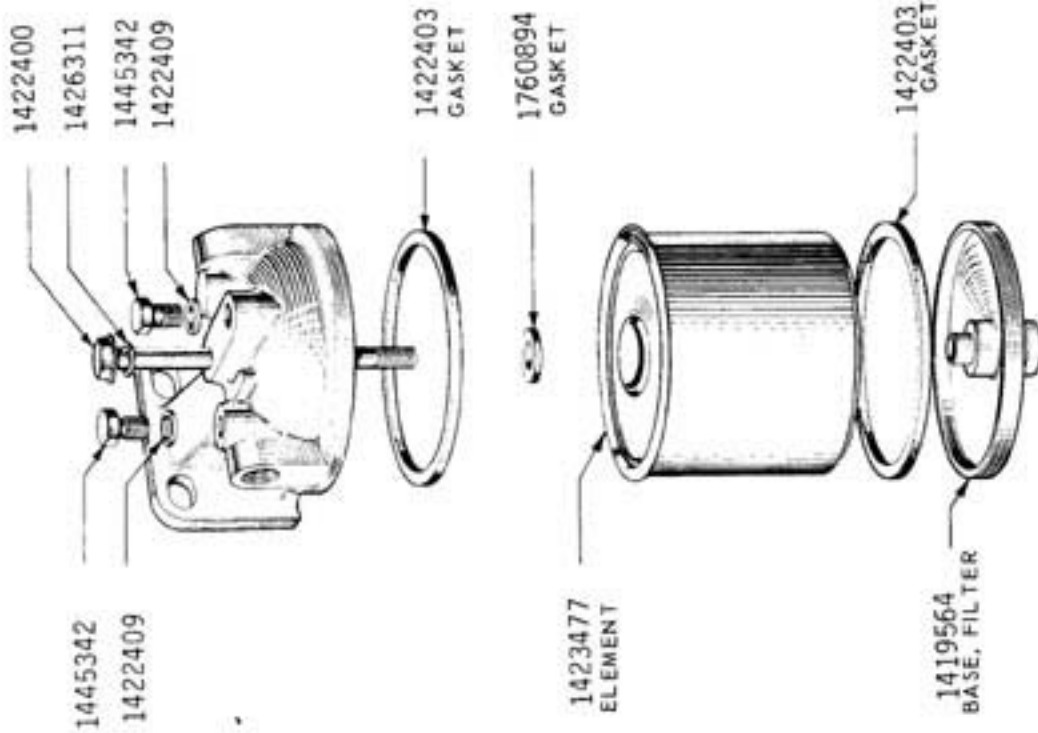

(KEY 213)

FUEL FILTER ASSEMBLY FOR E,F,G,H ENGINES  
 SIMMS SINGLE BOWL TYPE - Identification FH-60 or FH-73

- 1445341 Complete filter assembly
- 1423477 Element kit. Includes all items marked £.
- \* Use 1419562 on filters identified as FH-60.

# FUEL INJECTION PUMP

## Simms in-line type

KEY No. 220 - COMPLETE FUEL INJECTION PUMP (less key 221 idle damper)

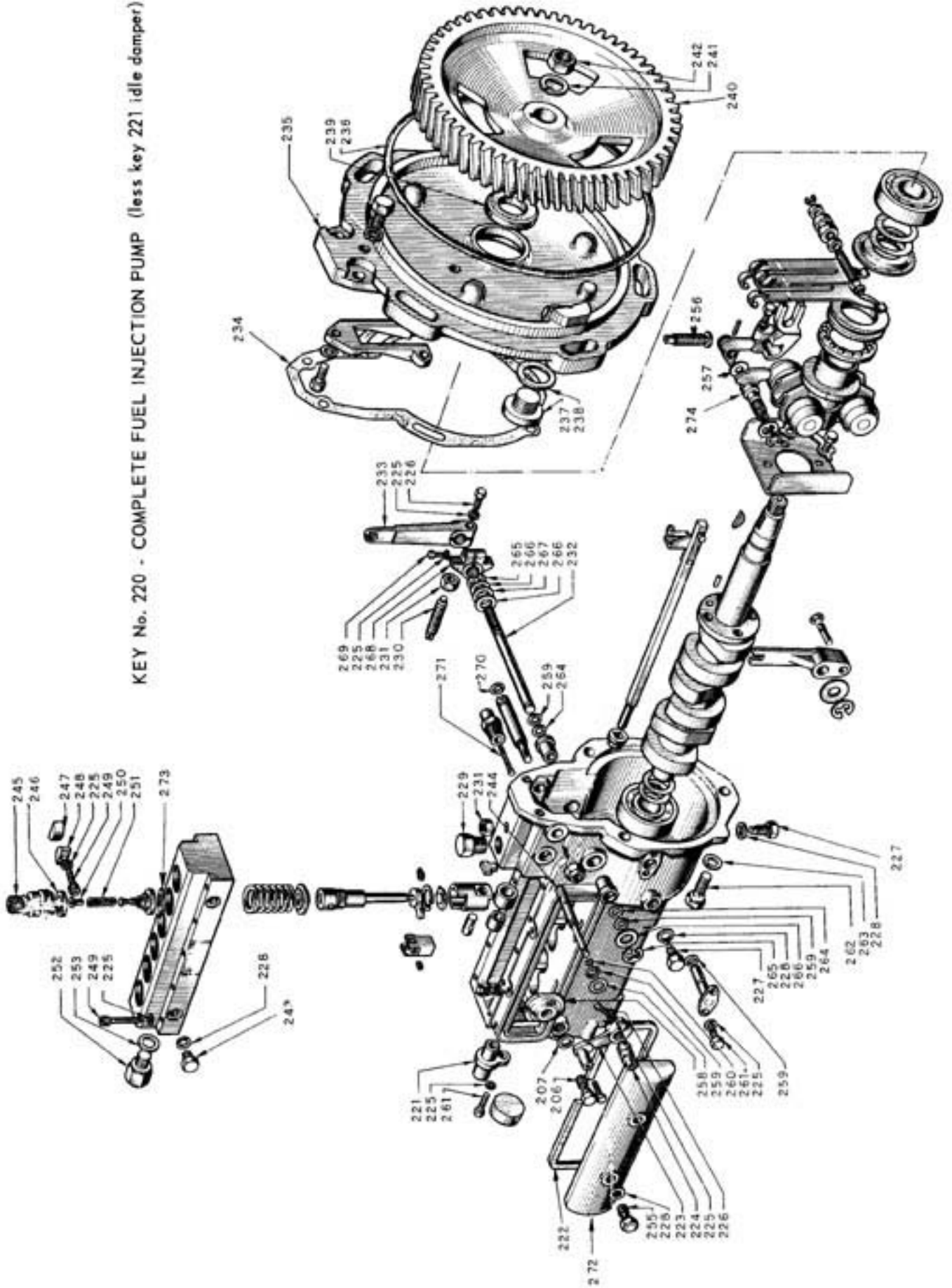

FUEL INJECTION PUMP  
C.A.V. Rotary type - Feb. '65 - Nov. 1969

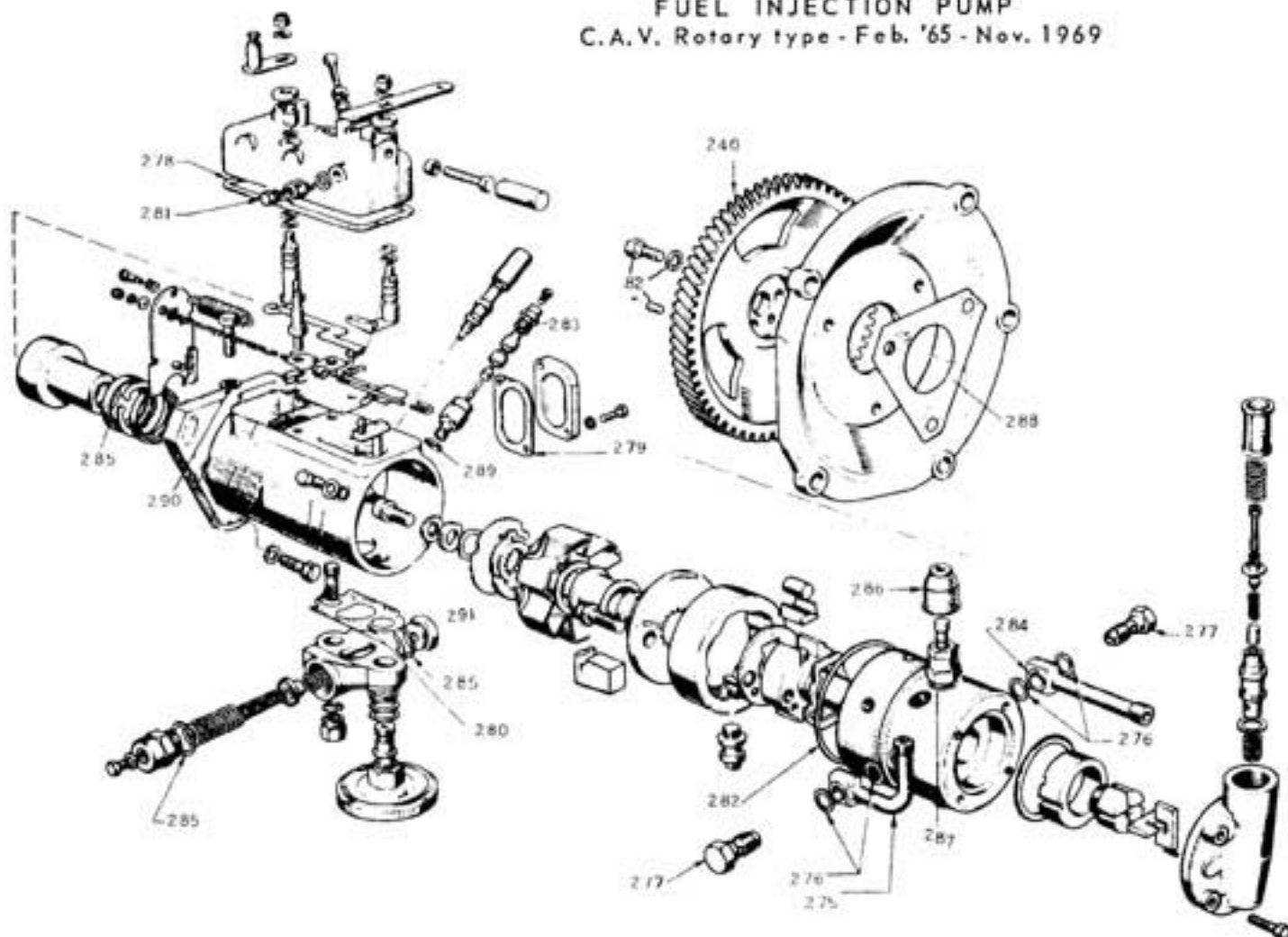

KEY	ENGINE	QUAN	CODE	PART NO.	DESCRIPTION
220	E	1	F	1762475	INJECTION PUMP (P4741)
220	F	1	F	1435976	INJECTION PUMP (P4742)
220	F	1	F	1400886	INJECTION PUMP, C.A.V.
220	G	1	F	6057111	INJECTION PUMP (P5128)
220	H	1	F	6057118	INJECTION PUMP (P5130)
220	I	1	F	6057107	INJECTION PUMP (P5060)
221	ALL	1	S	9000479	IDLE DAMPER, BOLT-ON TYPE
221	ALL	1	S	1575252	IDLE DAMPER, THREADED TYPE
222	EG	1	F	1762814	GASKET, COVER
222	FHI	1	F	1749944	GASKET, COVER
223	ALL	1	F	1772364	STOP LEVER
224	ALL	1	F	1749884	SHROUD
225	ALL	16/19	F	3415311	LOCKWASHER
226	ALL	2	F	1758598	SCREW
227	ALL	3	F	1584986	SCREW, DRAIN
228	ALL	7	F	1422409	WASHER
229	ALL	1	F	1720733	PLUG, OIL FILL
230	ALL	2	F	1481234	STOP SCREW

KEY	ENGINE	QUAN	CODE	PART NO.	DESCRIPTION	
231	ALL	3	L	OB25	NUT	
232	ALL	1	F	1409565	SHAFT, THROTTLE	
233	ALL	1	F	1772192	LEVER, THROTTLE	
234	ALL	1	F	1767545	GASKET	
235	ALL	1	F	1461587	COVER, GOVERNOR	
236	ALL	1	F	1719874	O RING, INJ. PUMP TO ENGINE	
237	ALL	1	F	1727582	PLUG, TIMING HOLE	
238	ALL	1	F	1766028	GASKET, TIMING HOLE	
239	ALL	1	F	1714566	SHAFT SEAL	
240	ALL	1	F	1568733	GEAR. USE WITH SIMMS INJ. PUMP	
240	ALL	1	F	1703843	GEAR. USE WITH C.A.V. INJ. PUMP	
241	ALL	1	L	OC-61	LOCKWASHER	
242	ALL	1	F	3415236	NUT	
243	ALL	2	F	1749751	SCREW, AIR VENT	
244	ALL	1	F	1772516	SHAFT, EXCESS FUEL	
245	EF	4/6	F	1749521	RETAINER, DELIVERY VALVE	
245	GHI	4/6	F	1476063	RETAINER, DELIVERY VALVE	
246	EF	4/6	F	1749822	WASHER, DELIVERY VALVE	
246	GHI	4/6	F	1476066	WASHER, DELIVERY VALVE	
247	ALL	2/3	F	3G49	CLAMP (WITH THREADED HOLE)	NOTE 1
248	ALL	2/3	F	3G49	CLAMP (WITH PLAIN HOLE)	NOTE 1
249	ALL	10/13	F	1749883	CLAMP SCREW	
250	ALL	4/6	F	1749391	REDUCER, VOLUME	
251	EF	4/6	F	1749391	SPRING, DELIVERY VALVE	
251	GHI	4/6	F	1421441	SPRING, DELIVERY VALVE	
252	ALL	1	F	1769705	ADAPTOR, FUEL INLET	
253	ALL	1	F	1760716	WASHER, ADAPTOR	
255	ALL	2	F	1759726	BOLT, COVER	
256	ALL	1	F	1749756	STOP SCREW	
257	ALL	1	F	1749622	SEAL, EXCESS FUEL SHAFT	
258	ALL	1	F	1762368	WASHER	
259	ALL	4	F	3416159	SEAL, 1/2" O.D.	
260	ALL	1	F	1720057	SEAL, 1/4" O.D.	
261	ALL	4	F	1479277	SCREW	
262	ALL	3	L	OE202	BOLT, 5/16 - 18 x 1"	
263	ALL	3	L	OC31	LOCKWASHER, 5/16"	
264	ALL	2	F	1779874	SEAL, CONTROL SHAFT	
265	ALL	3	F	1720915	CLIP	
266	ALL	3	F	1767558	WASHER, CONTROL SHAFT	
267	ALL	1	F	1788815	WASHER, CONTROL SHAFT	

KEY	ENGINE	QUAN	CODE	PART NO.	DESCRIPTION	
268	ALL	1	F	1767541	QUADRANT	
269	ALL	1	F	3425152	SCREW, QUADRANT	
270	ALL	1	F	1773618	SEAL, FULCRUM PIN	
271	ALL	1	F	1750078	SPRING	
272	EG	1	F	1762811	COVER	NOTE 1
272	EG	1	F	1546223	COVER, VENTED TYPE	
272	FHI	1	F	1749867	COVER	NOTE 1
272	FHI	1	F	1546222	COVER, VENTED TYPE	
273	GHI	4/6	F	1476072	O RING	
274	ALL	1	F	1772013	SHAFT	
275	F	1	F	1404004	CONNECTION OUTLET, ANGLE TYPE	
276	F	12	F	1700615	WASHER	
277	F	6	F	1412199	BOLT	
278	F	1	F	1700386	GASKET, HOUSING	
279	F	1	F	1706285	GASKET, COVER	
280	F	1	F	1727841	GASKET, HOUSING	
281	F	1	F	1700376	VENT SCREW	
282	F	1	F	1760918	SEAL, BODY	
283	F	1	F	1401625	VALVE, PRESSURIZING	
284	F	5	F	1795283	CONNECTION, OUTLET	
285	F	2	F	1760924	SEAL	
286	F	1	F	1700367	COVER (BOOT)	
287	F	1	F	1703934	WASHER	
288	F	1	F	1702457	GASKET	
289	F	1	F	1703971	WASHER	
290	F	1	F	N.L.A.	WASHER	
291	F	1	F	1795285	PLUG	

NOTE 1: USED WITH KEY 204 LEAK-OFF PIPE. DISCONTINUED FEB. 1975.

## FUEL INJECTOR

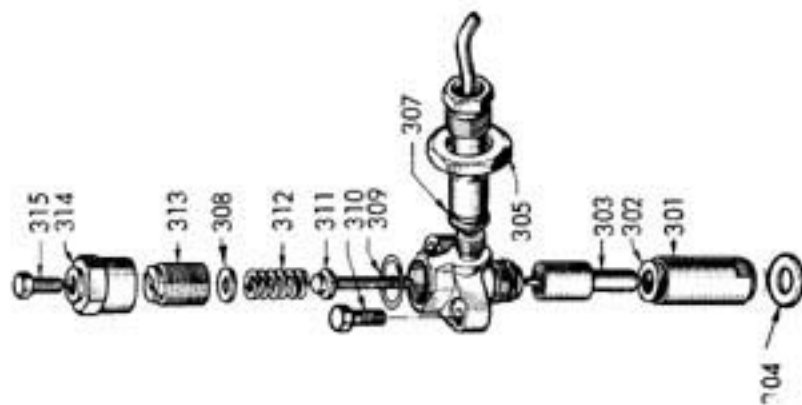

KEY	ENGINE	QUAN	CODE	PART NO.	DESCRIPTION
300	EFGH	4/6	F	1529252	INJECTOR ASSEMBLY
300	I	6	F	1529253	INJECTOR ASSEMBLY
301	ALL	4/6	F	1700364	KEY 305 NOZZLE
302	ALL	4/6	F	1700362	NUT, INJECTOR NOZZLE
303	EFGH	4/6	F	1540209	SHIM, INJ. NOZZLE
303	I	6	F	1540210	NOZZLE ASSY.
304	ALL	4/6	F	1707224	NOZZLE ASSY.
305	ALL	4/6	F	1791101	WASHER, SEALING
307	ALL	4/6	F	1791102	NUT, OIL SEAL RETAINING
308	ALL	4/6	F	1700351	SEAL
309	ALL	4/6	F	1502840	WASHER
310	ALL	8/12	F	1716286	WASHER, SEALING
311	ALL	6	F	1700361	BOLT 5/16-18 x 1 1/8"
312	ALL	4/6	F	1700354	SPINDLE & CAP ASSY.
313	ALL	4/6	F	1502694	SPRING
314	ALL	4/6	F	1502694	SCREW, SPRING ADJUSTING
315	ALL	4/6	F	1715904	NUT, INJ. SPRING CAP
.	ALL	4/6	F	1713504	BOLT, LEAK-OFF
.	ALL		F		TOOL, INJECTOR REMOVING

KEY No. 300 - COMPLETE INJECTOR  
 KEY No. 300A - COMPLETE INJECTOR ASSY.  
 LESS NOZZLE.

## FUEL (LIFT) PUMP

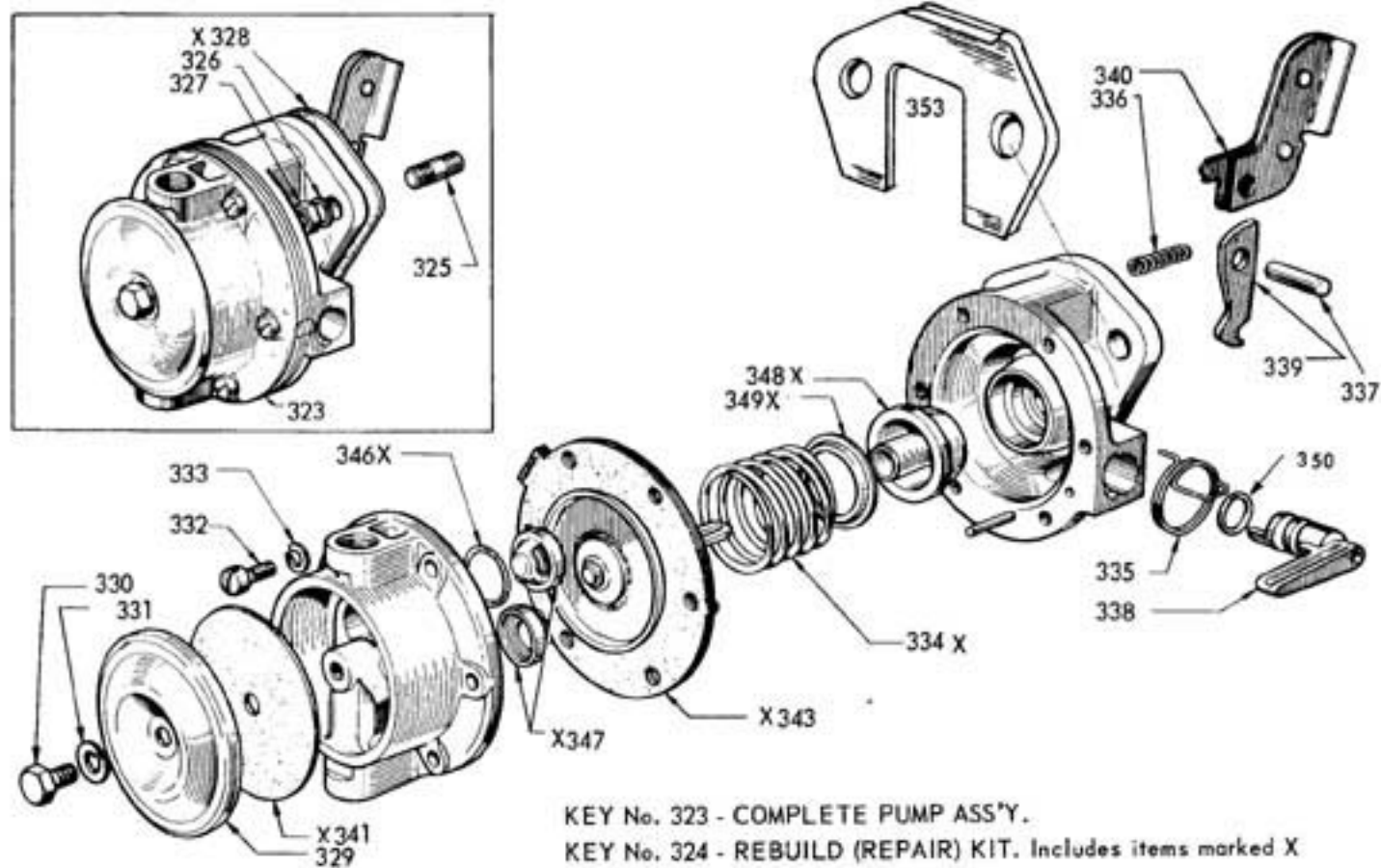

## FUEL LIFT PUMP, TURBO ONLY

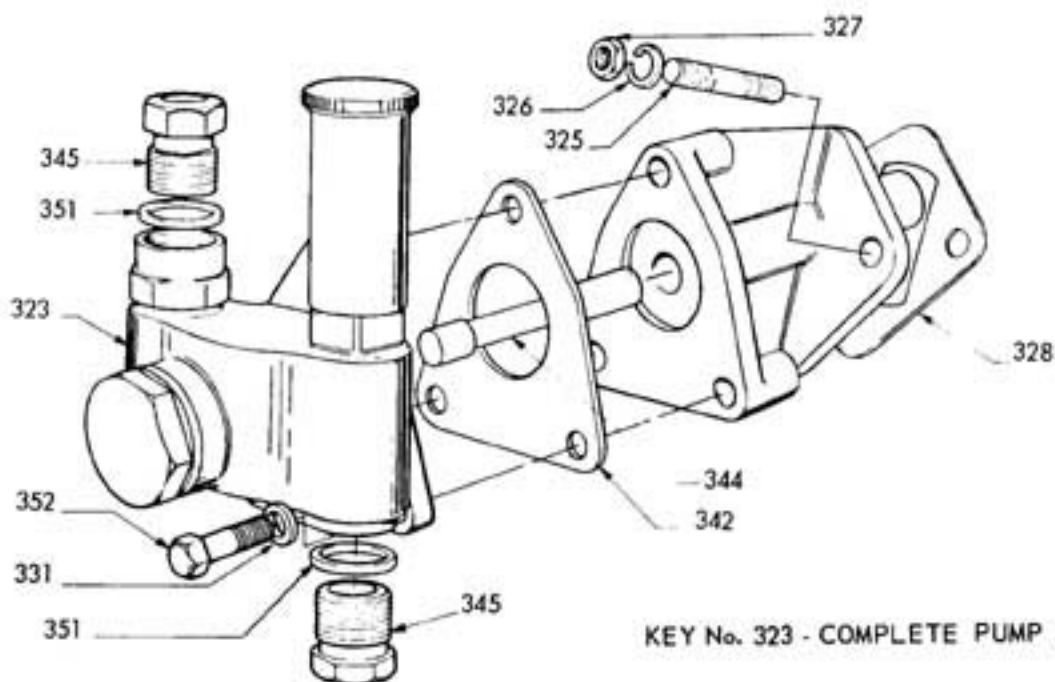



KEY	ENGINE	QUAN	CODE	PART NO.	DESCRIPTION
323	EFGH	1	F	6038718	FUEL PUMP
323	I	1	F	1536780	FUEL PUMP
324	EFGH	1	F	1563606	KIT, DIAPHRAGM & VALVE (FOR CONTENTS SEE PARTS MARKED X ON ILLUSTRATION)
325	ALL	2	L	00-15	STUD, 5/16-24 x 18 x 1 1/8
326	ALL	2	L	0C-31	LOCKWASHER, 5/16
327	ALL	2	L	0B25	NUT, 5/16-24
327	ALL	2	F	1467349	NUT, 5/16-24 HALF-ROUND TYPE. USED WITH KEY 353 PLATE.
328	ALL	1	F	1789436	GASKET
329	EFGH	1	F	1749047	COVER
330	EFGH	1	F	1757233	BOLT, 1/4-28 x 3/8"
331	ALL	AR	L	0C-21	LOCKWASHER
332	EFGH	6	F	1472222	SCREW
333	EFGH	6	F	1703778	LOCKWASHER
334	EFGH	1	F	6039027	SPRING
335	EFGH	1	F	1405313	SPRING, HAND PRIMER
336	EFGH	1	F	1749182	SPRING, ROCKER ARM
337	EFGH	1	F	1749177	PIN, ROCKER ARM
338	EFGH	1	F	1749193	LEVER, HAND PRIMING
339	EFGH	1	F	1401104	LINK
340	EFGH	1	F	1703732	ROCKER ARM
341	ALL	1	F	1791854	PULSATOR (DIAPHRAGM)
342	I	1	F	1501698	GASKET
343	EFGH	1	F	6039028	DIAPHRAGM
344	I	1	F	6018119	PLJUNGER
345	I	2	F	1501527	BUSHING
346	EFGH	1	F	1749061	GASKET

KEY	ENGINE	QUAN	CODE	PART NO.	DESCRIPTION
347	EFGH	2	F	1706711	VALVE
348	EFGH	1	F	1707225	SEAL
349	EFGH	1	F	1405317	RETAINER
350	EFGH	1	F	1748715	O RING
351	I	2	F	1503882	WASHER
352	I	3	L	0E101	BOLT, 1/4-20 x 5/8
353	GHI	1	F	1459154	PLATE, FUEL PUMP FLANGE

### WATER PUMP (FRESH WATER)

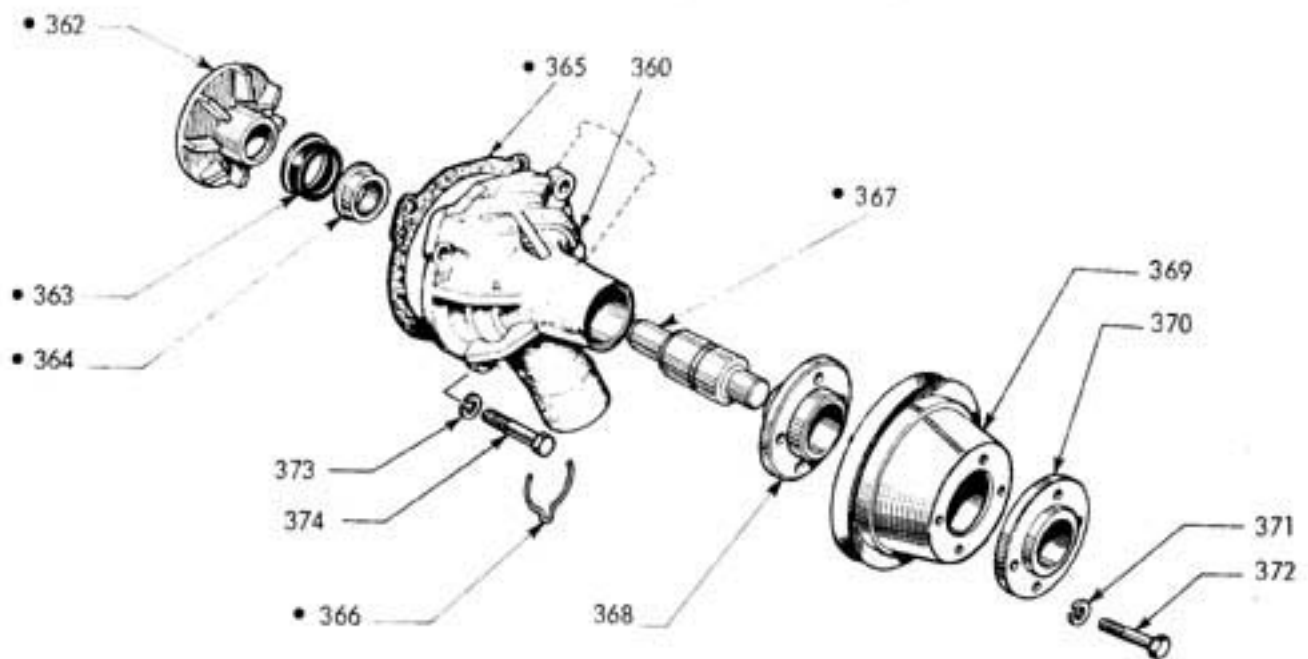

KEY 360 - COMPLETE PUMP ASSY.

KEY 361 - PUMP OVERHAUL KIT. Includes items marked •.

KEY	ENGINE	QUAN	CODE	PART NO.	DESCRIPTION
360	EPGH	1	F	5004985	WATER PUMP ASSY.
360	I	1	F	1468672	WATER PUMP ASSY. 2 O'CLOCK TYPE
361	ALL	1	F	1468677	KIT, PUMP REPAIR, INCLUDES ITEMS MARKED ●
362	ALL	1	F	1468675	● IMPELLER
*	GH	1	F	1467293	● SEAT, PUMP IMPELLER
363	ALL	1	F	1467294	● SEAL
364	ALL	1	F	1711755	● SLINGER
365	ALL	1	F	1467070	● GASKET
366	ALL	1	F	1711767	● RETAINER
367	ALL	1	F	1711754	● SHAFT & BEARING ASSY.
368	ALL	1	F	1788367	HUB
369	ALL	1	F	1711744	PULLEY, 4 1/2" O.D.
369	EG	1	F	1422360	PULLEY, 5 1/2" O.D.
370	ALL	1	F	1788282	SPACER (USED TO 7/74)
371	ALL	4	L	0C31	LOCKWASHER, 5/16"
372	ALL	4	F	1715834	BOLT, 5/16-24 x 1"
372	ALL	4	F	1568477	BOLT, 5/16-24 x 1 3/8"
373	ALL	4	L	0C-31	LOCKWASHER, 5/16"
374	ALL	4	L	0E203	BOLT, 5/16-18 x 1 1/4"

NOTE 1

NOTE 1: USED WITH KEY 370 SPACER (TO 7/74).

## STARTING MOTOR

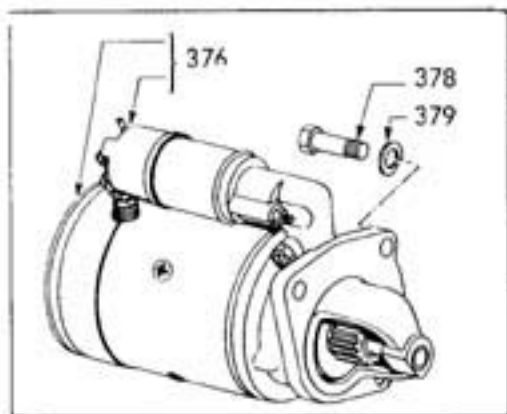
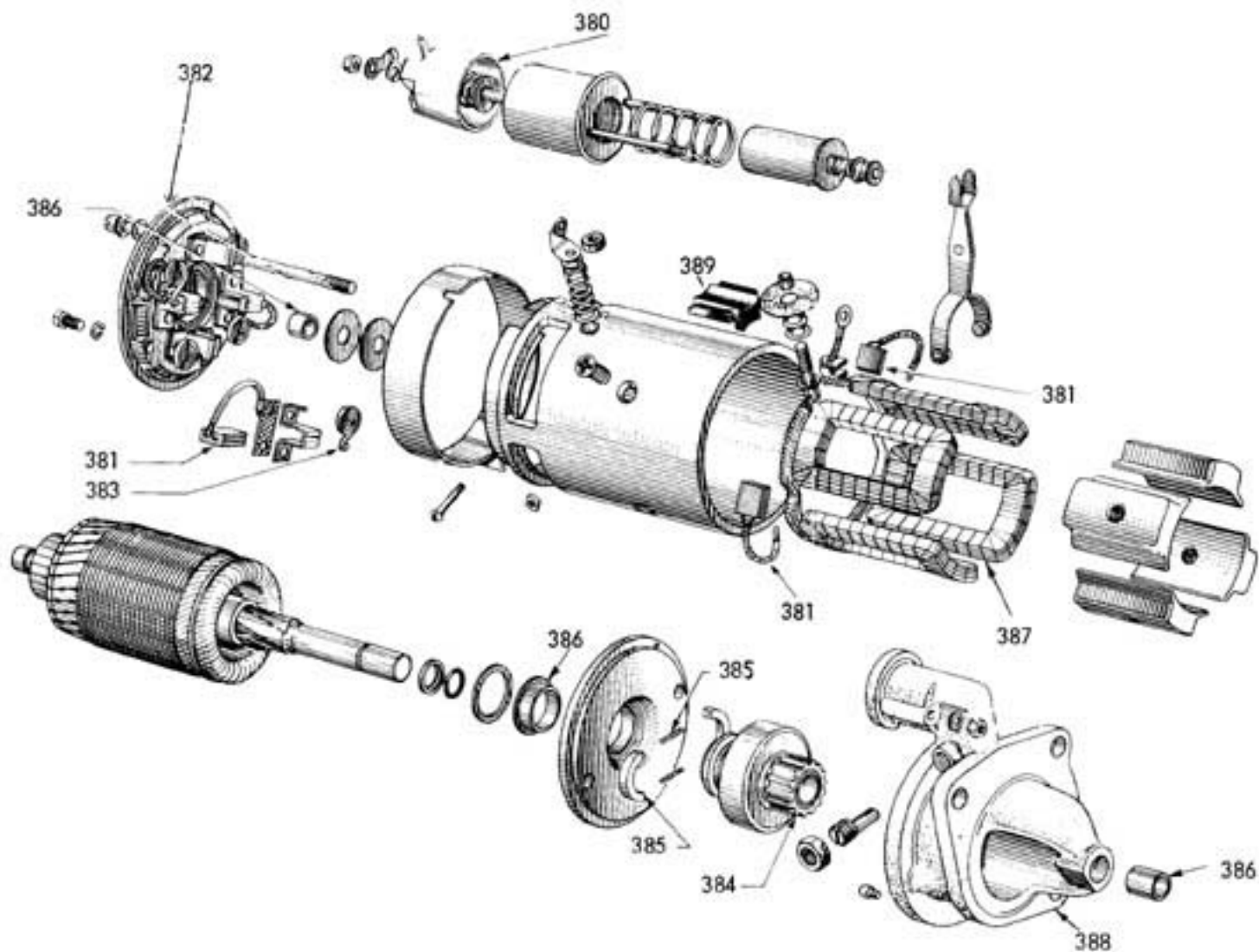

KEY 376 - COMPLETE STARTER, DRIVE and SOLENOID ASSY.  
 KEY 377 - COMPLETE SOLENOID ASSY.

KEY	ENGINE	QUAN	CODE	PART NO.	DESCRIPTION
376	ALL	1	F	1513727	STARTER, DRIVE & SOLENOID
377	ALL	1	F	1460981	SOLENOID ASS'Y.
378	ALL	3	L	0E302	BOLT, 3/8-16 x 1"
379	ALL	3	L	0C41	LOCKWASHER, 3/8"
380	ALL	1	F	1416050	CAP, SOLENOID
381	ALL	1	F	1739175	BRUSH KIT (4 BRUSHES). FOR STARTERS USING BRUSHES 25/32" x 11/32" x 1".
381	ALL	1	F	1712447	BRUSH KIT (4 BRUSHES). FOR STARTERS USING BRUSHES 23/32" x 5/16" x 7/8".
382	ALL	1	F	1739166	END PLATE KIT. INCLUDES ALL ITEMS MARKED X.
383	ALL	4	F	1739191	SPRING, BRUSH
384	ALL	1	F	1527421	STARTER DRIVE ASSY. (12 INTERNAL SPLINES)
384	ALL	1	F	1542237	STARTER DRIVE ASSY. (3 INTERNAL SPLINES)
385	ALL	1	S	1739118	SHOE, BRAKE (PR) AND SPRINGS
386	ALL	1	S	54243853	BUSHING KIT (3)
387	ALL	1	F	1553856	FIELD COILS (SET)
388	ALL	1	F	1527445	HOUSING, STARTER DRIVE
389	ALL	1	F	1739005	SEAL, SOLENOID
*	ALL	1	F	407	DECAL (12 VOLT, NEG. GROUND)

## TURBOCHARGER

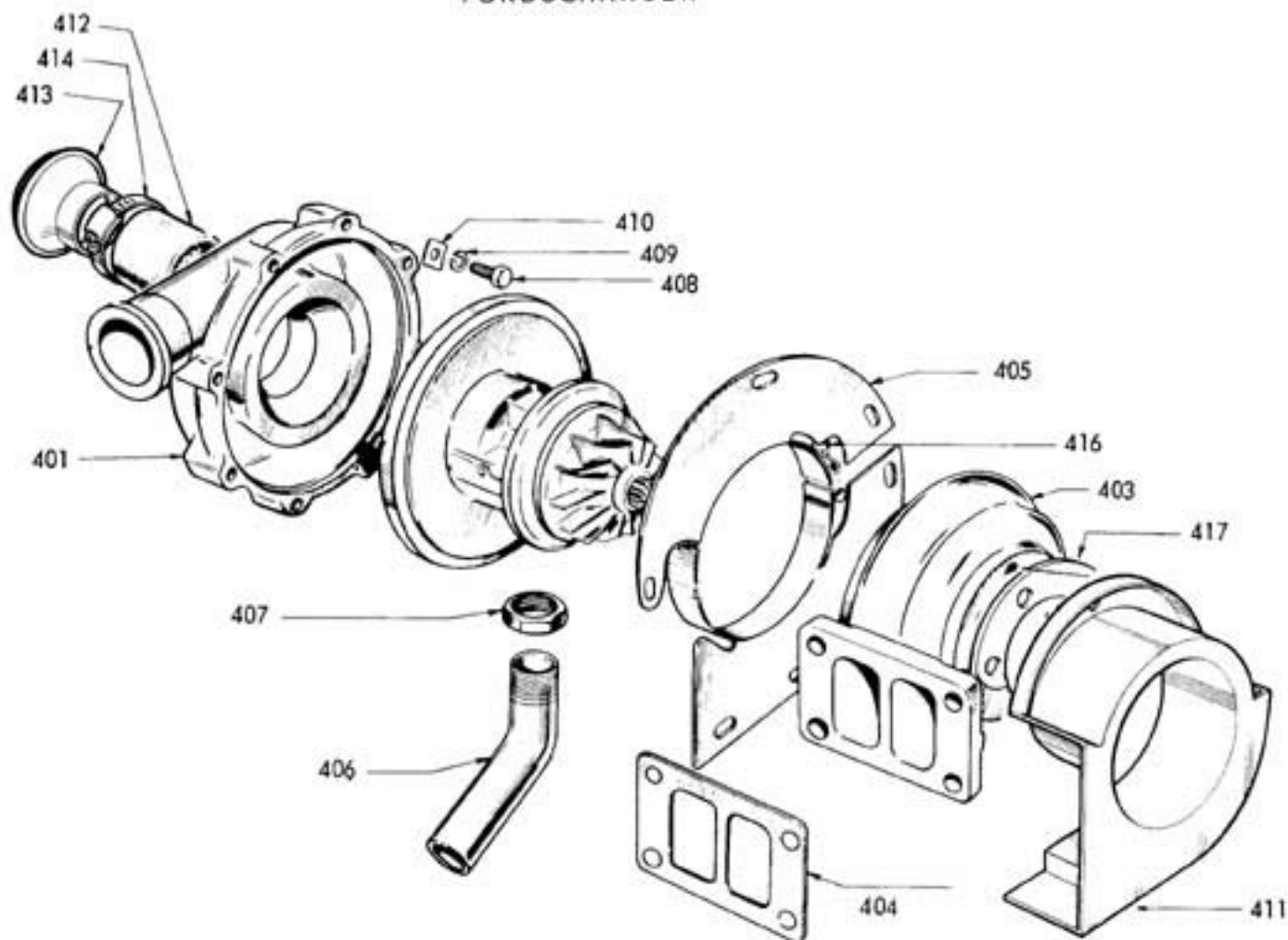

Complete turbocharger assembly - Key 400

KEY	ENGINE	QUAN	CODE	PART NO.	DESCRIPTION
400	I	1	F	6092653	TURBOCHARGER ASSY.
401	I	1	F	1468321	CASING, TURBO COMPRESSOR
403	I	1	F	1461717	CASING, TURBINE
404	I	1	F	1420460	GASKET
405	I	1	F	1510462	PLATE, HEAT SHIELD
406	I	1	F	1599466	CONNECTION, OIL DRAIN
407	I	1	F	1457824	LOCKNUT
408	I	8	F	1457824	BOLT
409	I	8	F	1568871	LOCKWASHER
410	I	8	F	1457461	CLAMP, COMPR. CASING

## A36

KEY	ENGINE	QUAN	CODE	PART NO.	DESCRIPTION
411	I	1	F	458211	CASE, HEAT SHIELD
•	I	7	F	1575224	BOLT, HEAT SHIELD
•	I	7	F	9C21	LOCKWASHER, HEAT SHIELD
412	I	1	F	1456626	HOSE, AIR CLEANER
413	I	1	F	1456620	AIR CLEANER
414	I	2	L	3K5	CLAMP, HOSE
417	I	1	F	1419786	GASKET