



Models 11850-0711
11850-0701

SELF-PRIMING PUMPS

PARTS LIST

Key	Description	Qty.	Part Number
1	Screw End Cover	6	91026-0010
2	End Cover	1	12346-0000
3	Gasket*	1	8641-0000
4	Screw (Plug)	1	91030-0100
5	Body	1	11854-0410
6	Screw (Cam)	1	91030-0110
7	Impeller Assembly*	1	1210-0001
8	Cam Assembly	1	8528-0000
9	Wearplate	1	8493-0000
10	Seal (Rotary)*	1	96080-0080
11	Washer	1	12019-0000
12	Bearing Seal	1	93000-0090
13	Pulley	1	5668-0010
14	Ball Bearing	1	92600-0070
15	Retaining Ring	1	18714-0000
16	Key†	1	91401-0030
17	Retainer†	1	8526-0000
18	Shaft†	1	11977-0000
19	Screw†	1	91095-0320
	Service Kit (Not Shown)		90117-0001

* Parts supplied in Service Kit.

† Parts supplied in Shaft Kit.

DISASSEMBLY

- Remove end cover screws, end cover and gasket.
- Remove impeller by grasping hub with water pump pliers.
- Loosen cam screw and remove cam (clean off sealant).
- Remove wearplate.
- Insert a screwdriver in each opening of drain area between seal seat and brass washer. Using lever action against seal seat, force seal forward into impeller bore.

If you have a stiff wire or welding rod approximately 1/8" diameter, bend 1/4" long right angle on two 6" lengths, and using in same manner as screwdriver, force seal out of seal bore completely.

If you do not have stiff wire available, pull seal out of bore by grasping outside of protruding seal with pliers.
- Remove seal seat and brass washer with hooked wire.
- Insert a screwdriver into "E" ring and hook it off the shaft.
- Slide pulley from shaft.
- Remove Woodruff Key.
- Remove bearing to body retaining ring.
- Pressing on impeller drive end of shaft, remove shaft and bearing assembly.
- Supporting bearing inner race, press shaft through bearing.
- Insert screwdriver through impeller side of body and push out bearing seal through bearing end.

CROSS SECTION

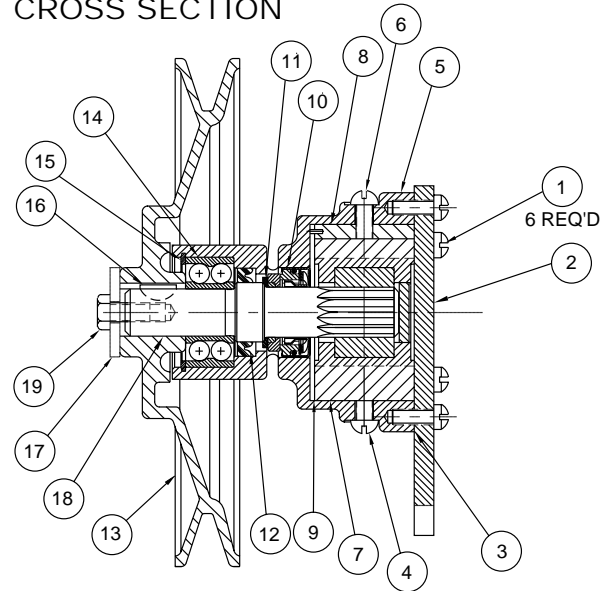

ASSEMBLY

- Lubricate bearing seal with water pump grease or equivalent and push into body bearing seal bore with the lip facing away from bearing.
- Press shaft into bearing. Use care to support inner race of bearing.
- Press Woodruff Key into shaft key way.
- Insert splined end of shaft into bearing bore and, pressing on bearing outer race, press bearing into bore.
- Install bearing to body retaining ring in body groove with flat side toward bearing.
- While supporting splined end of shaft, push pulley onto shaft.
- Push "E" ring into groove in shaft.
- Slide washer over splined end of shaft and down to shoulder.
- Slide seal seat and gasket assembly with rubber inward over shaft and down against washer. Lubricate with water (do not use oil) to ease assembly.
- With carbon facing in toward seat, press seal into bore. NOTICE: Press on outer-most edge of seal to prevent damage and press flush with bottom of body impeller bore.
- Install wearplate in body.
- Apply a thin coat of sealant to screw threads, top side and back end of cam and install in body with cam screw. Be sure to align pin in cam with hole in wearplate.
- Lubricate impeller bore with a light coat of water pump grease and start impeller into bore with a rotary motion, until splines engage, then push into bore.
- Install gasket and end cover and secure with end cover screws.

Models 11850-0711, 11850-0701

OPERATING INSTRUCTIONS

WARNING	Injury hazard. Exposed pulleys and belts can cause injury. Install shield around pulleys and belts. Stay clear while machinery is operating.
----------------	---

1. **INSTALLATION** - The rotation of the pump shaft and the location of the cam determines the location of the pump's intake and discharge ports (refer to Dimensional Drawing). Before installing, turn the pump shaft in the direction of the operating rotation.
2. **DRIVE BELT** - Over tight belt or pulley misalignment will reduce pump bearing life.
3. **SPEEDS** - Designed for full range of engine speeds.
4. **SELF-PRIMING** - Primes at low or high speeds. **BE SURE SUCTION LINES ARE AIRTIGHT OR PUMP WILL NOT SELF-PRIME.**
5. **RUNNING DRY** - Unit depends on liquid pumped for lubrication. **DO NOT RUN DRY** for more than 30 seconds. Lack of liquid may damage the impeller.
6. **TEMPERATURES** - Standard impeller is designed to handle liquid temperatures between 45° and 180°F.
7. **FREEZING TEMPERATURES** - Drain unit by loosening end cover. Most methyl alcohol (methanol) based antifreezes can be used.

DO NOT USE PETROLEUM BASED ANTI-FREEZE COMPOUNDS OR RUST INHIBITORS.
8. **GASKET** - Use standard pump part. A thicker gasket will reduce priming ability. A thinner gasket will cause impeller to bind.
9. **SPARE PARTS** - A JABSCO Service Kit 90117-0001 should be kept on hand to service all but the most badly worn pumps.

HEAD/FLOW TABLE

Head Pressure PSI (kg/cm ²)	I Pump Speed I RPM)					
	500	1160	1750	2450	3000	3600
8.7 (0.61)	2.8 (10.6)	7.5 (28.4)	11.7 (44.3)	17.0 (64.3)	21.0 (79.5)	25.7 (97.3)
13.0 (0.91)	2.0 (7.6)	7.0 (26.5)	11.0 (41.6)	16.0 (60.6)	19.5 (73.8)	24.4 (92.4)
21.6 (1.52)		8.6 (32.6)	13.4 (50.7)	17.0 (64.3)	21.4 (81.0)	

FLOW IN U.S. GPM (liters/min)

Typical flow in average engine cooling applications having discharge pressures of 10 - 15 psi and intake vacuums of 3 - 5 inches of mercury.

Model 11850-0701 may be used to replace the following models:

- 11850-0101 - See notes 3 and 4
- 11850-0511 - See notes 1 and 3
- 11850-0811 - See notes 2 and 4
- 11850-0911 - See notes 1 and 3

Model 11850-0711 maybe used to replace the following models:

- 11850-0411 - See notes 1 and 3
- 11850-0801 - See notes 2 and 4
- 11850-0901 - See notes 2 and 3

- Note 1 May require modification of end cover if mounting clearance is not adequate (see dimensional drawing).
- Note 2 Originally fit with a round end cover - Now obsolete.
- Note 3 End cover must be rotated 180°.
- Note 4 May require re-using original pulley from pump being replaced.

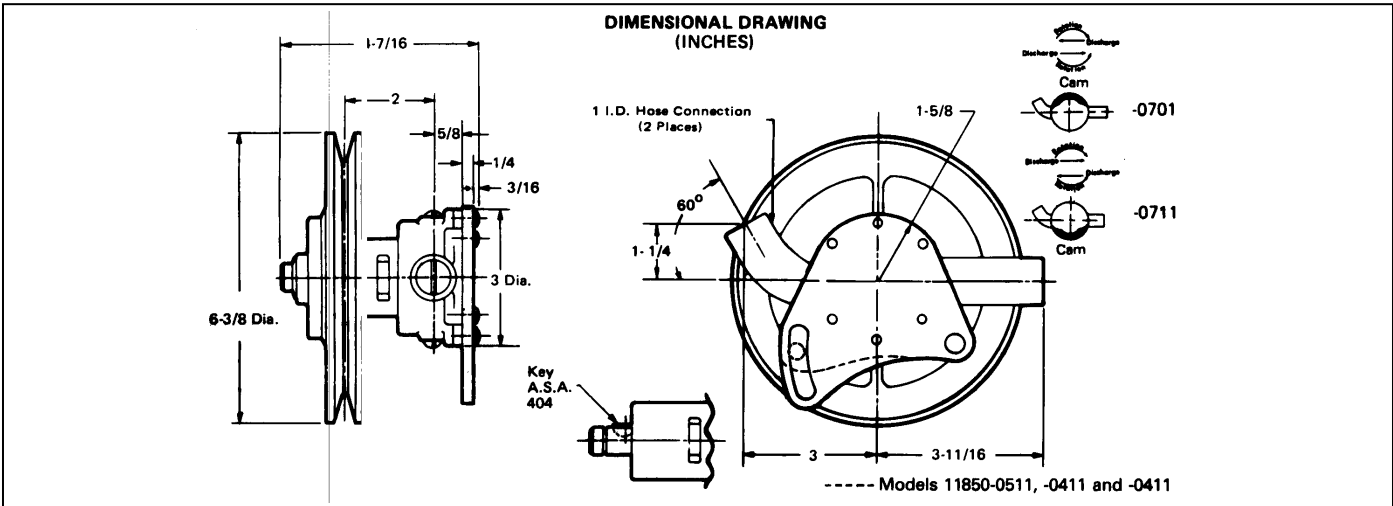

Jabsco



THE PRODUCTS DESCRIBED HEREIN ARE SUBJECT TO THE JABSCO ONE YEAR LIMITED WARRANTY, WHICH IS AVAILABLE FOR YOUR INSPECTION UPON REQUEST.

U.S.A.
Jabsco
1485 Dale Way, P.O. Box 2158
Costa Mesa, CA 92628-2158
Tel: 714.545.8251
Fax: 714.957.0609

UNITED KINGDOM
Jabsco
Bingley Road, Hoddesdon
Hertfordshire EN11 0BU
Tel: +44 (0) 1992 450145
Fax: +44 (0) 1992 467132

CANADA
Fluid Products Canada
55 Royal Road
Guelph, Ontario N1H 1T1
Tel: (519) 821.1900
Fax: (519) 821.2569

JAPAN
NHK Jabsco Company Ltd.
3-21-10, Shin-Yokohama
Kohoku-Ku, Yokohama, 222
Tel: 045.475.8906
Fax: 045.475.8908

GERMANY
Jabsco GmbH
Oststrasse 28
22840 Norderstedt
Tel: +49-40-53 53 73 -0
Fax: +49-40-53 53 73 -11