

SECTION B

PARTS IDENTIFICATION - LEHMAN MARINIZING PARTS

In order to provide a simple method of identification, all models included herein have been assigned a "code" letter as follows:

ENGINE CODE	CU/IN	No. CYLS.	YEARS	IDENTIFICATION
E	242	4	2/65-11/69	With cylinder liners
F	363	6	2/65-11/69	With cylinder liners
G	254	4	12/69-up	Less cylinder liners
H	380	6	12/69-up	Less cylinder liners
I	363	6	7/68-up	Turbocharged

For ease in locating parts, refer to pictorial index on following page or to index below.

Air filter	-----	page	B23
Alarm system	-----		B27
Alternator, Motorola 55 AMP	-----		B11, B12
Alternator, Motorola 72 AMP	-----		B13
Aperature cover	-----		B21
Belt, vee	-----		B23
Cooler, oil	-----		B14
Exchanger, heat	-----		B8
Fuel line (flexible)	-----		B23
Hoses, water	-----		B8, B18, B23
Manifold, 6 cylinder	-----		B4
Manifold, 4 cylinder	-----		B6
Manuals, instruction, shop, etc.	-----		B29
Miscellaneous	-----		B23
Mountings, engine	-----		B19
Piping, fresh water	-----		B8
Piping, raw water	-----		B18
Pump drive assembly	-----		B17
Pump, water	-----		B16
Riser, exhaust	-----		B26
Solenoid, starter relay	-----		B22
Spare parts kits	-----		B28
Stop engine controls	-----		B24, B25
Supports, engine	-----		B19
Tachometer adaptor	-----		B9
Tank, expansion	-----		B10
Throttle control brackets	-----		B24, B25
Transmission adaption	-----		B20
Water heater connection kit	-----		B27

By reference to the drawing on the applicable page, select the required part and note the "key" number assigned to it. The key number will be repeated in the listing of parts following the drawing. The second column indicates the engine to which the part applies per the engine code letters shown above. The third column shows the quantity required per engine.

The fourth "code" column indicates the manufacturer of the subject part per the following:

CODE	MANUFACTURER
F	Ford Motor Company
T	Jabsco Pump Company
L	Lehman Power Corporation.
P	Paragon Gear Works
S	Simms (Jas. Lucas Co.)
W	Warner Gear Division
BY	Motorola, Inc.

WHEN ORDERING PARTS SEE INSTRUCTIONS ON PAGE 2

INDEX TO LEHMAN MARINE EQUIPMENT

PICTORIAL INDEX

PAGE NUMBERS ARE SHOWN ON DRAWINGS BELOW

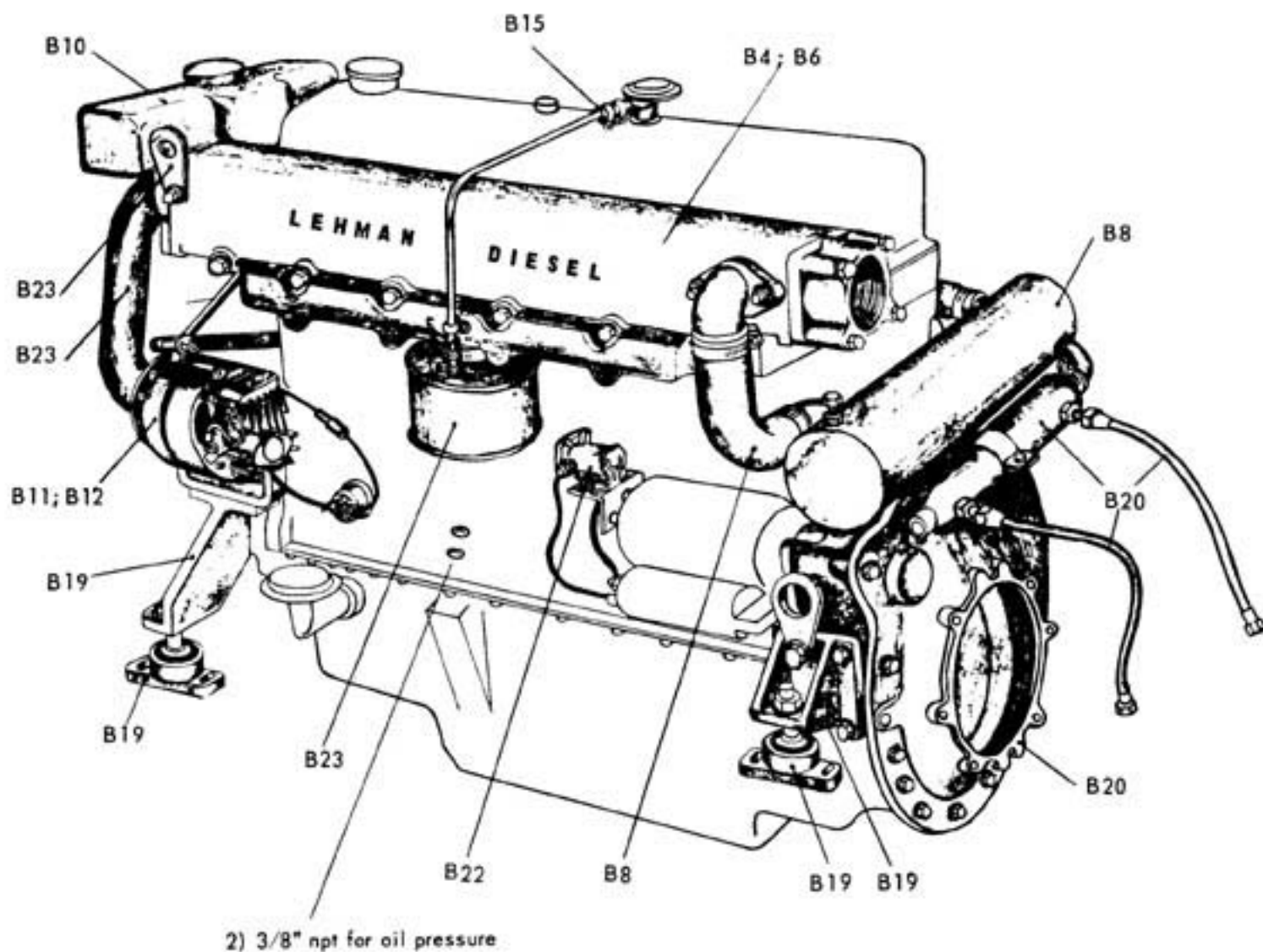

INDEX TO LEHMAN MARINE EQUIPMENT

PICTORIAL INDEX

PAGE NUMBERS ARE SHOWN ON DRAWINGS BELOW

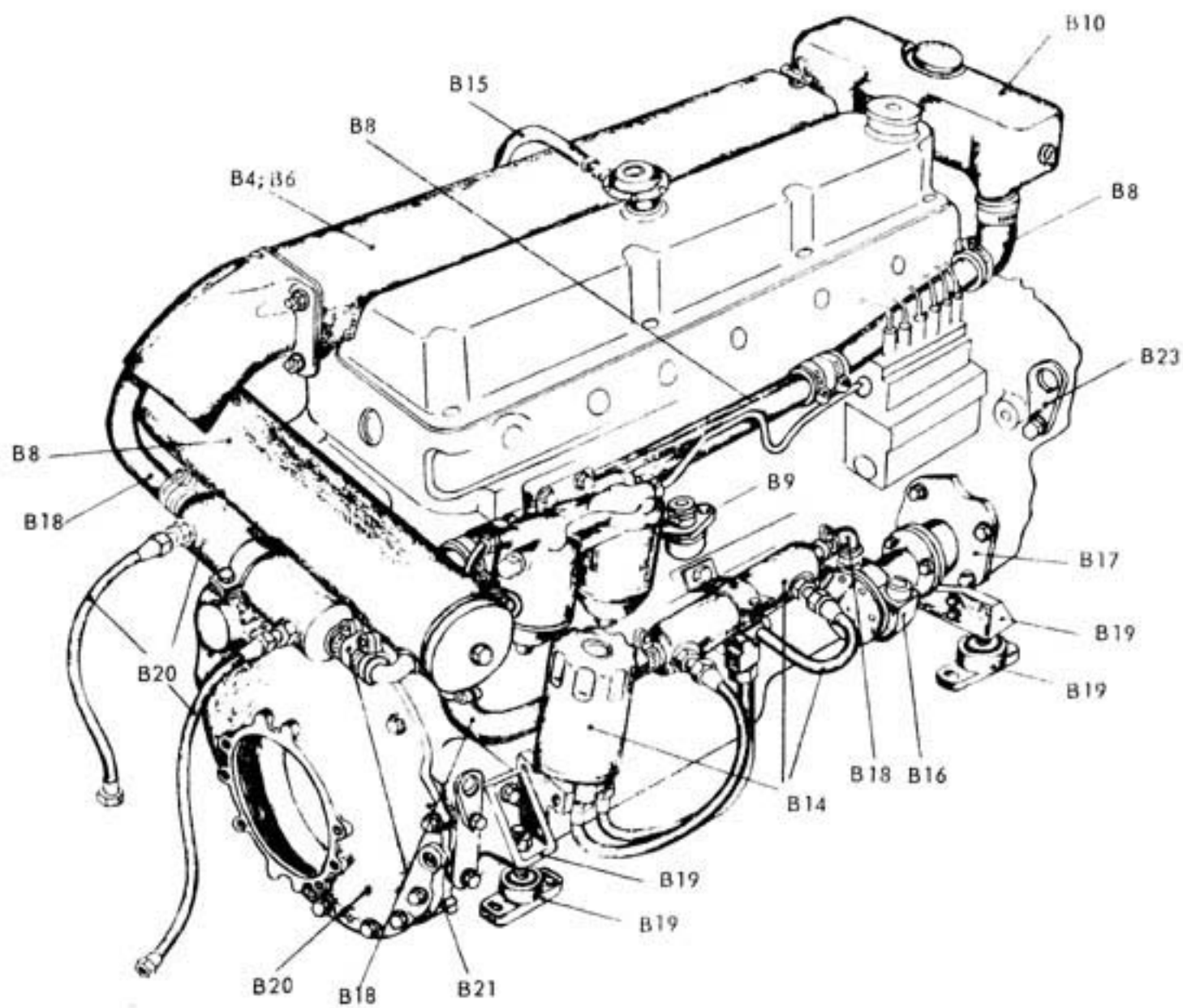

6 CYLINDER MANIFOLD

6 CYLINDER MANIFOLD

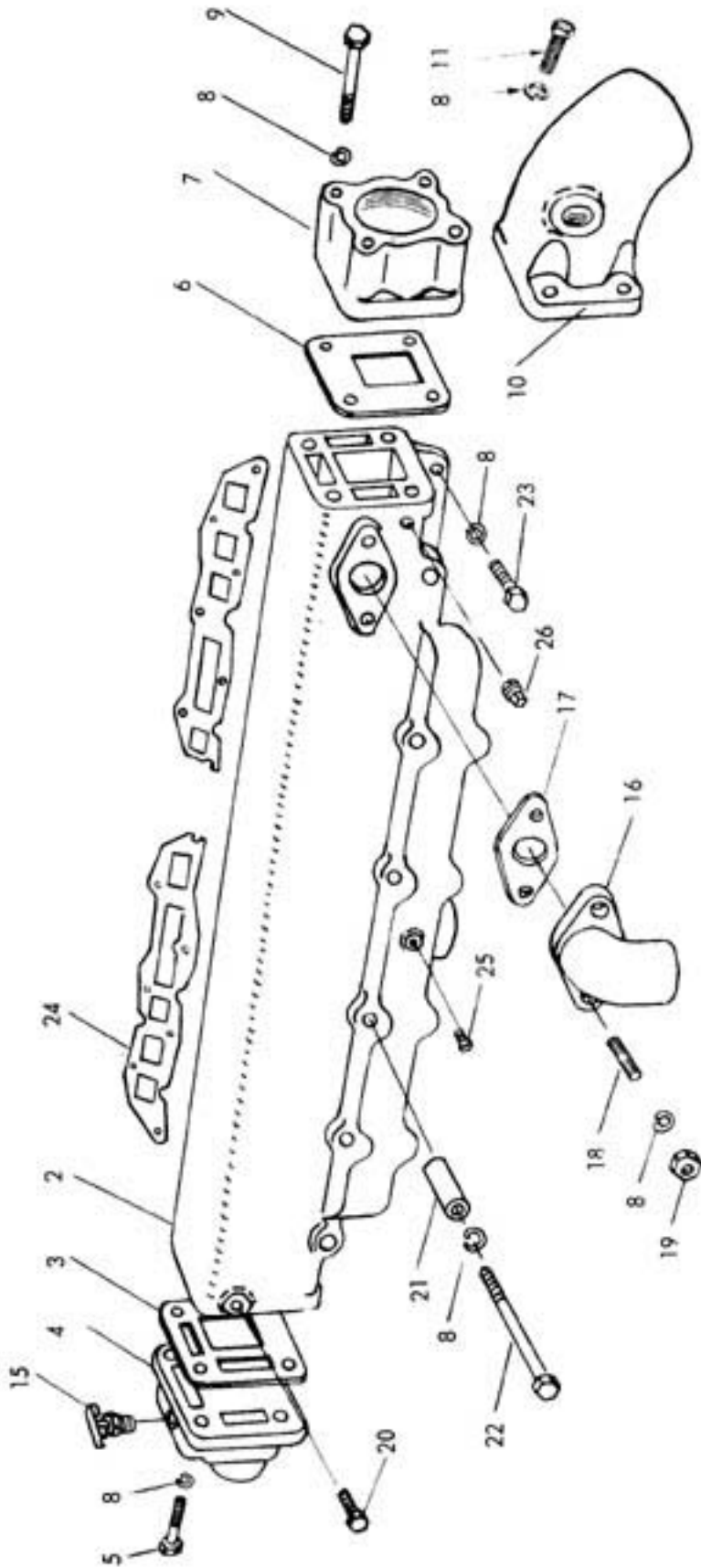

KEY No. 1 - Complete assembly

6 CYLINDER MANIFOLD

KEY	ENGINE	QUAN	CODE	PART NO.	DESCRIPTION
1	FHI	1	L	D1100	MANIFOLD ASSY. (WITH 3" NPT STRAIGHT EXHAUST)
1	FHI	1	L	D1100-A	MANIFOLD ASSY. (WITH 3" NPT EXHAUST ELBOW)
2	FHI	1	L	1A288	MANIFOLD BODY (550)
3	ALL	1	L	1C27	GASKET, FRONT
4	ALL	1	L	1A231	FRONT FLANGE (446)
5	ALL	4	L	OE303	BOLT, 3/8-16 x 1 1/4"
6	ALL	1	L	1C26	GASKET, REAR
7	FH	1	L	1A223	EXHAUST FLANGE, 3" NPT (432)
8	ALL	AR	L	OC41	LOCKWASHER, 3/8"
9	FH	4	L	OE307 1/2	BOLT, 3/8-16 x 2 3/4"
10	FH	1	L	1A283	EXHAUST ELBOW, 3" NPT (538)
10	FH	1	L	1A371	EXHAUST ELBOW-HOSE 3-1/2 " ID (731)
11	ALL	4	L	OE303-C	BOLT, 3/8-16 x 1-1/4"
15	ALL	1	L	3J2	PEYCOCK
16	ALL	1	L	1A230	ELBOW, WATER CIRCULATION (445)
17	ALL	1	L	2D21	GASKET
18	ALL	2	L	OD41	STUD, 3/8 x 1 5/8"
19	ALL	2	L	OB34	NUT, 3/8-16
20	ALL	1	L	OE302-C	BOLT (LIFTING RING)
21	ALL	6	L	1B59	SLEEVE COUPLING
22	ALL	6	L	OE309.5	BOLT, 3/8-16 x 3 3/4"
23	ALL	7	L	OE303	BOLT, 3/8-16 x 1 1/4"
24	FH	2	L	2D28	GASKET, MANIFOLD TO HEAD
24	I	2	F	1418493	GASKET, MANIFOLD TO HEAD (TURBO)
25	FHI	1	L	OA16	SCREW, #10-32 x 5/16"
26	ALL	1	L	3L2	PLUG, 1/8 NPT

4 CYLINDER MANIFOLD

4 CYLINDER MANIFOLD ASSEMBLY

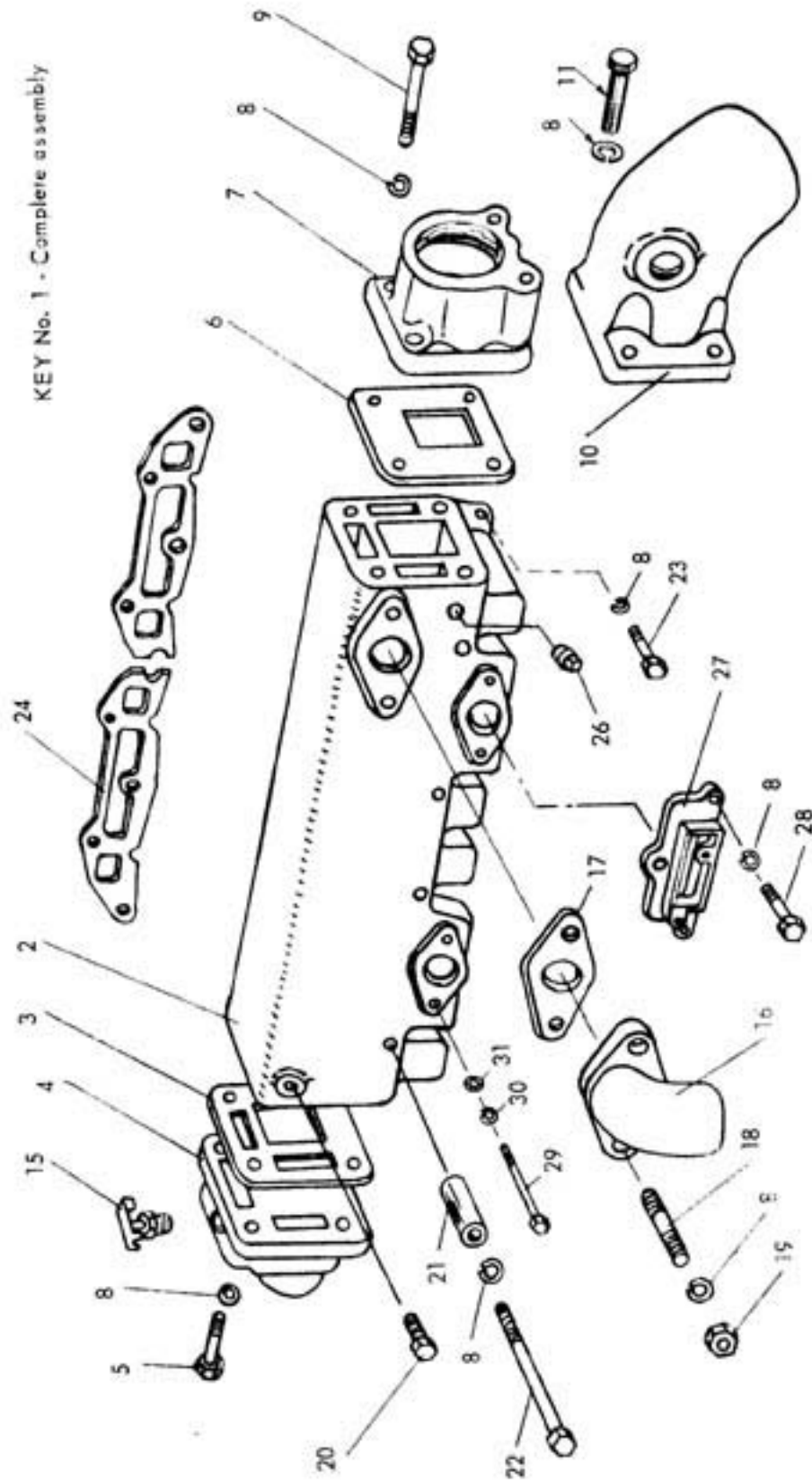

4 CYLINDER MANIFOLD

KEY	ENGINE	QUAN	CODE	PART NO.	DESCRIPTION
1	EG	1	L	D1102	MANIFOLD ASSY (WITH 2 1/2" NPT STRAJGHT EXHAUST)
1	EG	1	L	D1102-A	MANIFOLD ASSY, (WITH 2 1/2" NPT EXHAUST ELBOW)
2	EG	1	L	1A241	MANIFOLD BODY (469)
3	ALL	1	L	1C27	GASKET, FRONT
4	ALL	1	L	1A231	FRONT FLANGE (446)
5	ALL	4	L	OE303	BOLT, 3/8-16 x 1 1/4"
6	ALL	1	L	1C26	GASKET, REAR
7	EG	1	L	1A222	EXHAUST FLANGE, 2 1/2" NPT (431)
8	ALL	AR	L	OC41	LOCKWASHER, 3/8"
9	EG	2	L	OE304	BOLT, 3/8-16 x 1 1/2"
9	EG	2	L	OE307	BOLT, 3/8-16 x 2 1/2"
10	EG	1	L	1A284	EXHAUST ELBOW, 2 1/2 NPT (547)
10	EG	1	L	1A372	EXHAUST ELBOW, HOSE 2-7/8" ID (731)
11	ALL	4	L	OE303C	BOLT, 3/8-16 x 1-1/4"
15	ALL	1	L	3J2	PETCOCK
16	ALL	1	L	1A230	ELBOW, WATER CIRCULATION (445)
17	ALL	1	L	2D21	GASKET
18	ALL	2	L	OD41	STUD, 3/8 x 1 5/8"
19	ALL	2	L	OB34	NUT, 5/8-24
20	ALL	1	L	OE302-C	BOLT (LIFTING RING)
21	ALL	4	L	1B59	SLEEVE, COUPLING
22	ALL	4	L	OE309	BOLT, 3/8-16 x 3 1/2"
23	ALL	5	L	OE303	BOLT, 3/8-16 x 1 1/4"
24	EG	2	L	2D27	GASKET, MANIFOLD TO HEAD
26	ALL	1	L	3L2	PLUG, 1/8 NPT
27	EG	2	L	1A291	ADAPTOR, AIR FILTER (557) USED UNTIL JUNE 1972 ONLY.
28	EG	6	L	OE302	BOLT, 3/8-16 x 1"
29	EG	4	L	OE109	BOLT, 1/4-20 x 2 1/4"
30	EG	4	L	OC21	LOCKWASHER, 1/4"
31	EG	4	L	OC20	WASHER, FLAT, 1/4"

HEAT EXCHANGER and PIPING ASSEMBLY

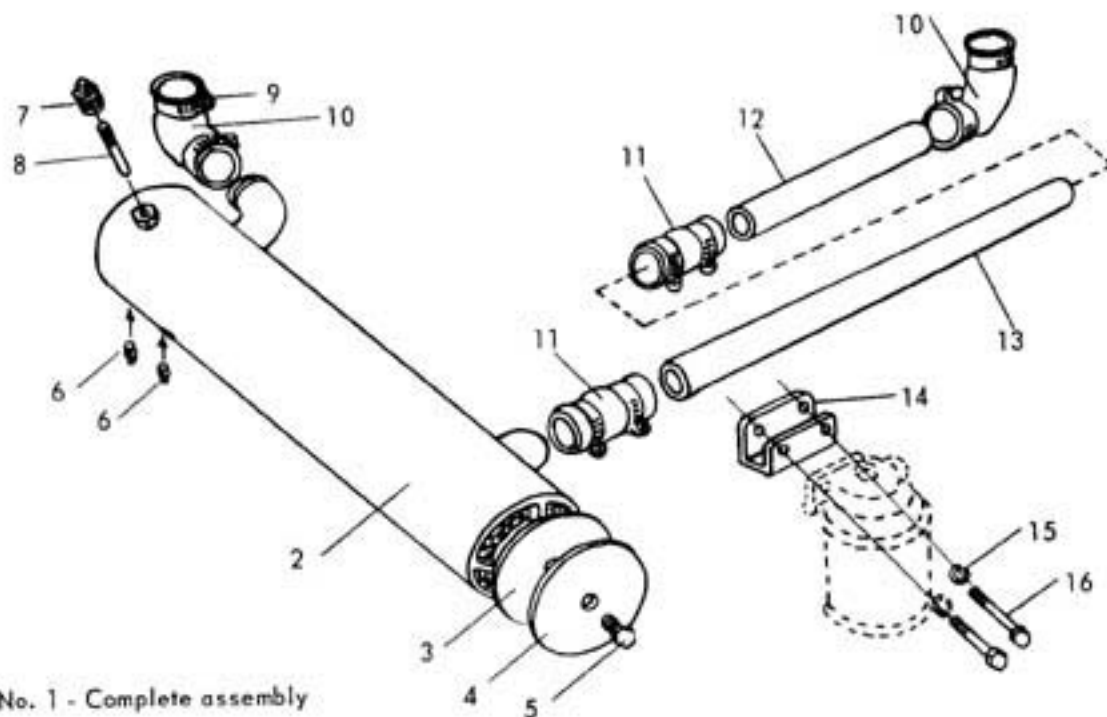

KEY No. 1 - Complete assembly

KEY	ENGINE	QUAN	CODE	PART NO.	DESCRIPTION
1	EG	1	L	D881	EXCHANGER ASSEMBLY
1	FHI	1	L	D880	EXCHANGER ASSEMBLY
2	EG	1	L	2C213	HEAT EXCHANGER, COPPER (NOTE 1)
2	EG	1	L	2C219	HEAT EXCHANGER, CUPRO-NICKEL (NOTE 1)
2	FH	1	L	2C211	HEAT EXCHANGER, COPPER (NOTE 1)
2	FH	1	L	2C218	HEAT EXCHANGER, CUPRO-NICKEL (NOTE 1)
2	I	1	L	2C225	HEAT EXCHANGER, COPPER (NOTE 1)
3	EG	2	L	2D24	GASKET, COVER
3	FH	2	L	2D25	GASKET, COVER
4	EG	2	L	2C213-A	COVER
4	FH	2	L	2C211-A	COVER
5	ALL	2	L	0E301-F	BOLT, 3/8-16 x 3/4 BRASS
6	ALL	2	L	3L1	PLUG, 1/8 NPT
7	ALL	1	L	EM21	ZINC PENCIL PLUG (NOTE 2)
8	ALL	1	L	EM21-A	ELEMENT, ZINC PENCIL
9	ALL	8	L	3K4	HOSE CLAMP
10	ALL	2	L	3K503	HOSE ELBOW
11	ALL	2	L	3K213 (3)	HOSE, 1 3/4 ID x 3"
12	EG	2	L	1D39	WATER TUBE, 1 3/4 x 10"
12	FHI	1	L	1D39	WATER TUBE, 1 3/4 x 10"

KEY	ENGINE	QUAN	CODE	PART NO.	DESCRIPTION
13	FHI	1	L	1D26	WATER TUBE, 1 3/4 x 20"
14	EFGH	1	L	1A233	SPACER, FUEL FILTER (NOTE 3)
15	EFGH	2	L	OC41	LOCKWASHER, 3/8" (NOTE 3)
16	EFGH	2	L	OE308	BOLT, 3/8-16 x 3" (NOTE 3)

NOTE 1: INCLUDES KEY NUMBERS 3 THROUGH 8.

NOTE 2: INCLUDES KEY 8.

NOTE 3: USED WITH SINGLE TYPE FILTER ONLY (UNTIL DEC. 1971)

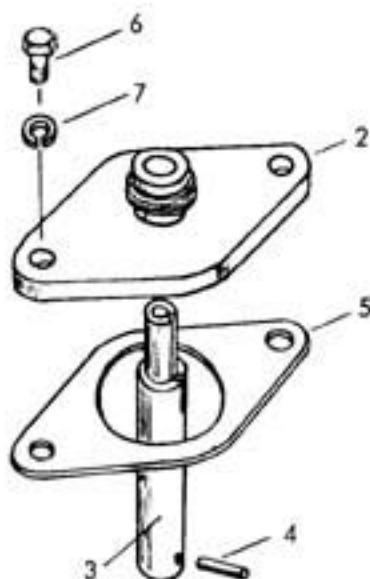

TACHOMETER ADAPTOR

Key No. 1 - Complete Assembly

KEY	ENGINE	QUAN	CODE	PART NO.	DESCRIPTION
1	ALL	1	L	D160	TACHOMETER ADAPTOR
2	ALL	1	L	1A337	HOUSING, TACH. ADAPTOR (630)
3	ALL	1	L	1B62	DRIVE SHAFT (INCLUDES KEY 4)
4	ALL	1	L	2K209	ROLL PIN
5	ALL	1	L	2D21	GASKET
6	ALL	2	L	OE102	BOLT, 1/4-20 x 3/4"
7	ALL	2	L	OC21	LOCKWASHER, 1/4"
*	ALL	1	L	2F211	CAP, TACH. DRIVE SEALING (PLASTIC)

EXPANSION TANK ASSEMBLY

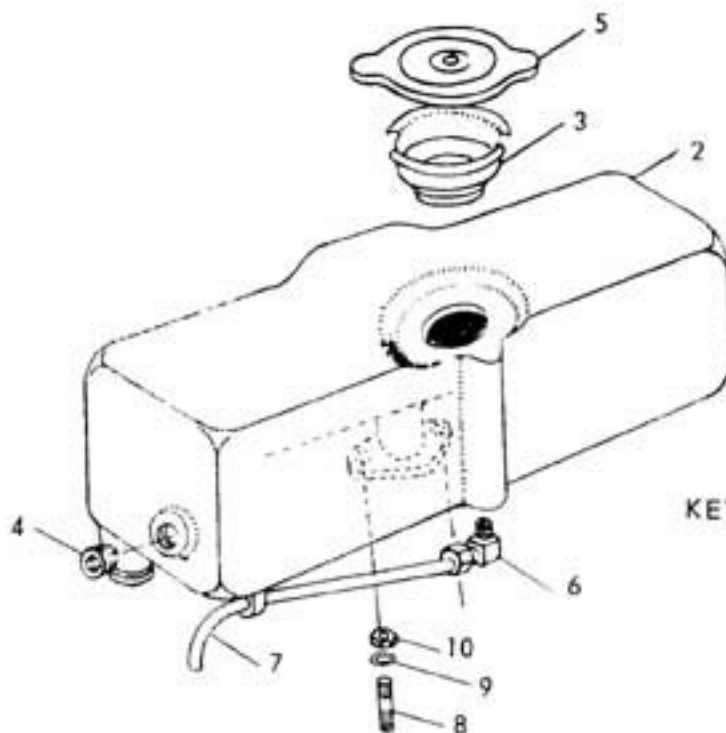

KEY No. 1 - Complete assembly

KEY	ENGINE	QUANT	CODE	PART NO.	DESCRIPTION
1	ALL	1	L	D876	EXPANSION TANK ASSY.
2	ALL	1	L	1A232	TANK (447)
3	ALL	1	L	2C300	NECK, FILLER
4	ALL	2	L	3L33	PLUG, 1/2" NPT
5	ALL	1	L	2C302	CAP, FILLER
6	ALL	1	L	3E150	ELBOW, TUBING
7	ALL	1	L	3A3-8.5	TUBE, OVERFLOW
8	ALL	2	L	OD10	STUD
9	ALL	2	L	OC31	WASHER, 5/16"
10	ALL	2	L	OB25	NUT, 5/16 -24
*	ALL		L	2M6	CLAMP, PLASTIC 1/4"
*	ALL		L	OA16	SCREW, #10-32 x 5/16"

* PARTS NOT SHOWN. USED UNTIL DECEMBER 1971 ONLY.

ALTERNATOR ASSEMBLY (Motorola)

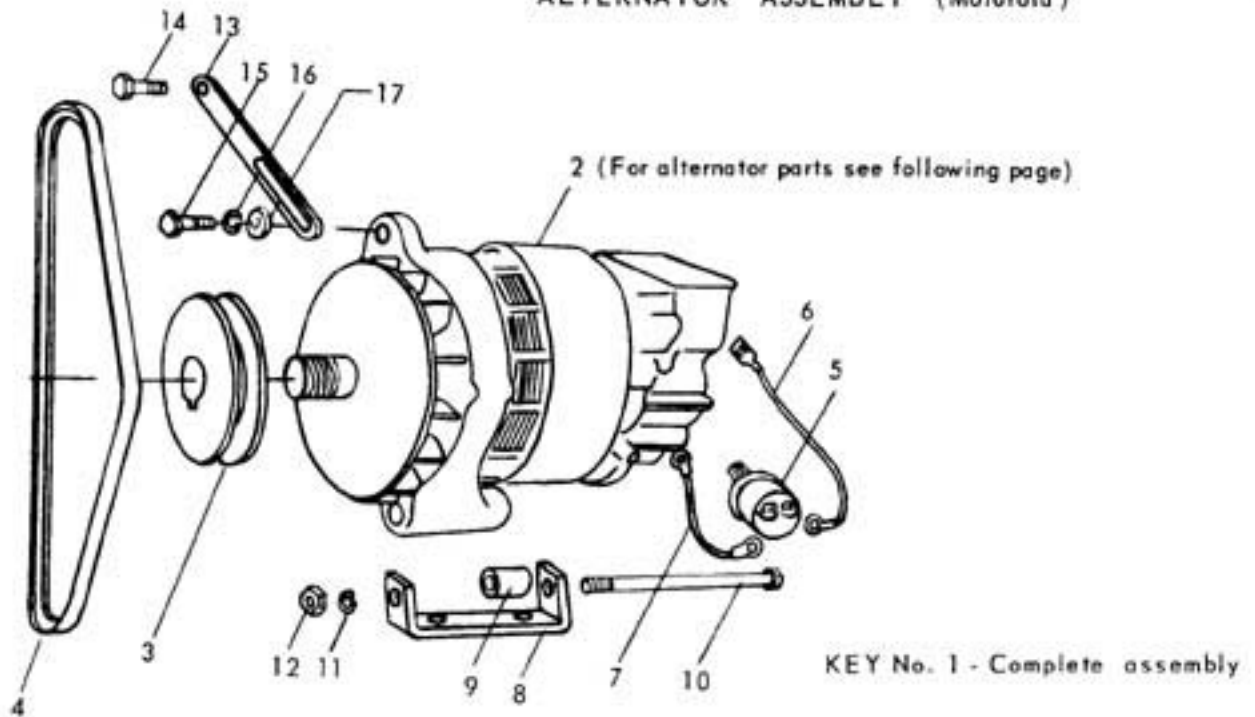

KEY No. 1 - Complete assembly

KEY	ENGINE	QUAN	CODE	PART NO.	DESCRIPTION
1	ALL	1	L	D143	ALTERNATOR ASSY.
2	ALL	1	L	2E3	ALTERNATOR/REGULATOR/FAN ASSY. (See following page for parts)
3	ALL	1	L	2B19	PULLEY
4	ALL	1	L	2B209	VEE BELT
5	ALL	1	L	2E206	OIL PRESSURE SWITCH
6	ALL	1	L	2E401	WIRE ASSY, RING x SPADE
7	ALL	1	L	2E400	WIRE ASSY, RING x RING
8	ALL	1	L	1E18	BRACKET, ALTERNATOR
9	ALL	1	L	1B64	SPACER, 3/8 x 5/8 x 7/8
10	ALL	1	L	OE310	BOLT, 3/8-16 x 4
11	ALL	1	L	OC41	LOCKWASHER, 3/8"
12	ALL	1	L	OB35	NUT, 3/8-16
13	ALL	1	L	2M7	TENSIONING (SLIDE) BRACKET
14	ALL	1	L	OE203	BOLT, 5/16-18 x 1 1/4
15	ALL	1	L	OE201-C	BOLT, 5/16-18 x 3/4
16	ALL	1	L	2M11	LOCKWASHER, 5/16"
17	ALL	2	L	2M12	WASHER, FLAT, 5/16"

PARTS FOR (2E3) MOTOROLA ALTERNATOR

All Lehman series 143 alternators may be serviced by any authorized Motorola distributor or repair facility. As all component parts are standard, no difficulty should be encountered securing same. When inquiring for parts or service, provide all data from nameplate on alternator. Lehman Manufacturing can provide the replacement parts indicated by asterik (*) on the following parts list.

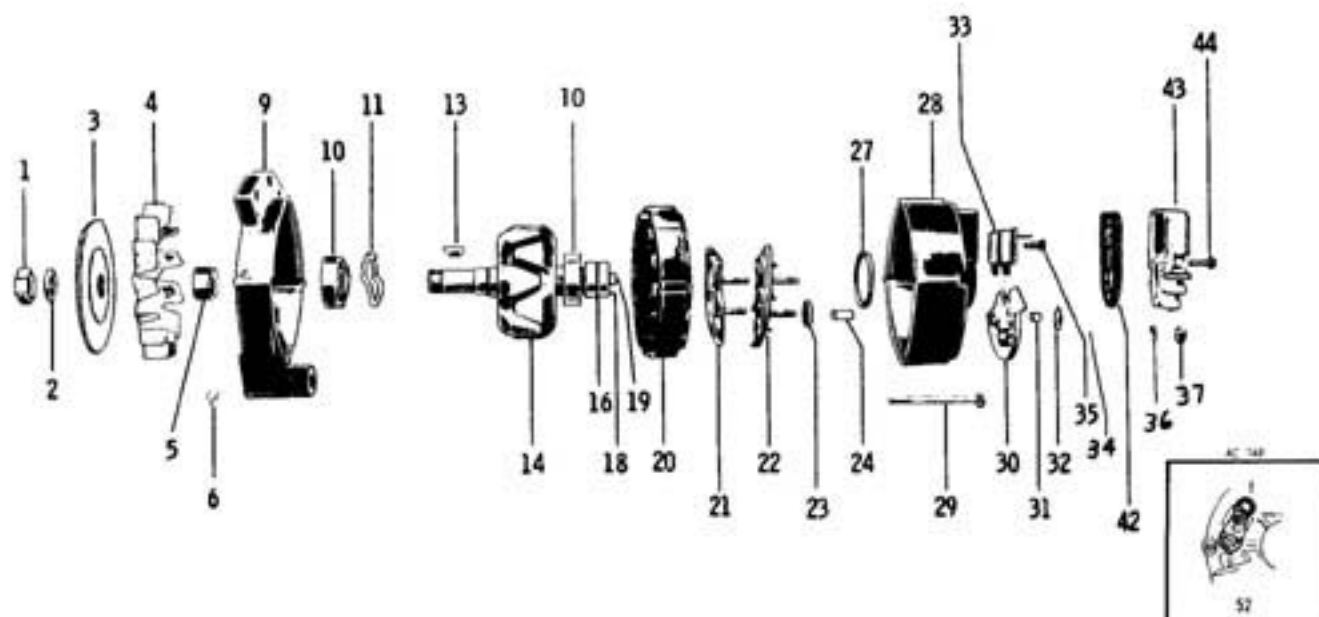

KEY No.	QUAN.	CODE	PART No.	DESCRIPTION
-	1	L	2E3	* Alternator, complete with fan
1	1	Motorola	20-136	Nut, pulley mounting, 5/8-18
2	1	Motorola	20-137	Washer, lock, 5/8
3	1	L	2B19	* Pulley
4	1	BY	7-68	* Fan
5	1	Motorola	20-152	Spacer, fan and pulley
6	4	Motorola	20-150	Nut, square, 10-32
9	1	Motorola	14-24	Housing, front
10	2	BY	11-21	* Bearing, front and rear
11	1	BY	11-3	* Retainer, front bearing
13	1	Motorola	20-7	Woodruff key, No. 5
14	1	Motorola	12-7	Rotor assembly
16	1	Motorola	12-22	Slip ring ass'y.
18	1	Motorola	20-111	Washer, lock, No. 10
19	1	Motorola	20-56	Screw, slip-ring retaining, 10-32
20	1	Motorola	13-3	Stator assembly
21	1	BY	1-18	* Diode ass'y., rect., neg.
22	1	BY	1-17	* Diode ass'y., rect., pos.
23	4	BY	15-4	* Washer, insulating, 1/2 x No. 10
24	2	BY	15-1	* Sleeve, insulating, 19/32 long
27	1	BY	11-26	* Retainer, rear bearing
28	1	Motorola	14-63	Housing, rear
29	4	Motorola	20-143	Bolt, 10-32 x 3 1/8
30	1	BY	1-30	* Diode ass'y., isolation, dual
31	1	Motorola	15-2	Sleeve, insulating, 3/32 long
32	1	Motorola	15-4	Washer, insulating, No. 10 x 1/2 o.d.
33	1	BY	3-7	* Brush assembly
34	8	Motorola	20-148	Locknut, 10-24
35	4	Motorola	20-116	Screw, 8-32 x 1/2
36	1	Motorola	20-113	Washer, lock, 1/4
37	1	Motorola	20-160	Nut, hex., 1/4-20
42	1	BY	3-14	* Gasket
43	1	BY	5-197	* Regulator R7-1
44	2	Motorola	20-117	Screw, reg. mounting
52	1	BY	2-17	Tachometer take-off (tap) kit

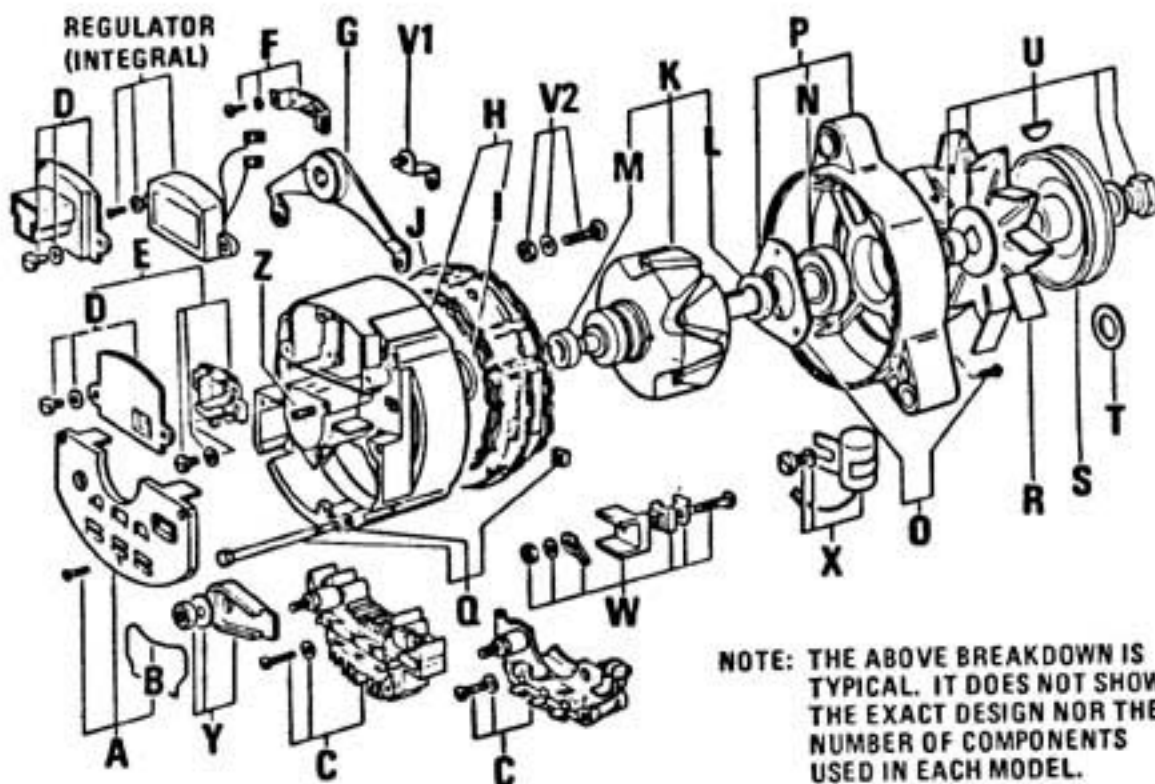

KEY	PART NO.	DESCRIPTION
	510-859	ALTERNATOR
	505-37	VOLTAGE REGULATOR
A	514-139	REAR COVER
B	--	CONNECTOR CLIP
C	501-43	BRIDGE ASSEMBLY
D	--	BRUSH COVER (ONLY)
E	503-12	BRUSH HOLDER ASSEMBLY
F	515-7	TERNINAL/BRACKET
G	--	REAR FOOT
H	514-212	REAR HOUSING ASSEMBLY
I	511-4	BEARING RETAINER (ONLY)
J	513-20	STATOR
K	512-45	ROTOR ASSEMBLY
L	NA	SPACER
M	11-23	REAR BEARING
N	11-21	FRONT BEARING
O	511-11	BEARING RETAINER (ONLY)
P	514-141	FRONT HOUSING ASSEMBLY
Q	520-92	THROUGH BOLTS (4)
R	507-55	FAN
S	507-101	PULLEY
T	--	SPACER
U	520-141	INSTALLATION KIT
V	--	GROUND TERMINAL ASSEMBLY
W	520-100	INS. TERMINAL ASSEMBLY
X	--	CAPACITOR
Y	--	B+ INSULATOR
Z	--	STUD

OIL COOLER / FILTER ASSEMBLY

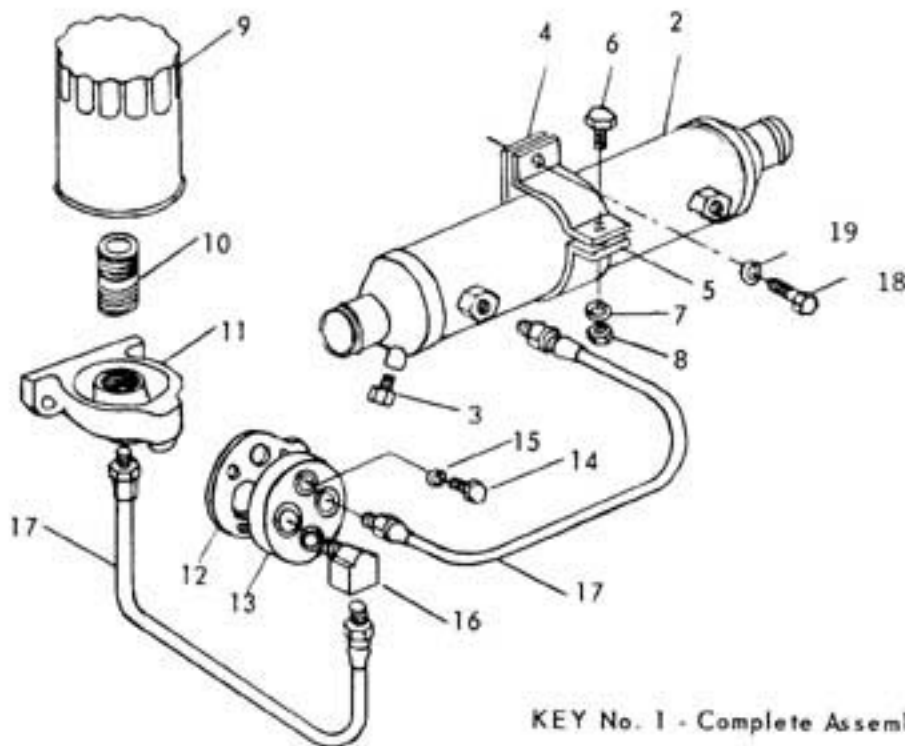

KEY No. 1 - Complete Assembly

KEY	ENGINE	QUAN.	CODE	PART NO.	DESCRIPTION
1	EG	1	L	D195B	OIL COOLER/FILTER ASSY.
1	FH	1	L	D195A	OIL COOLER/FILTER ASSY.
2	ALL	1	L	*2C207	OIL COOLER, COPPER, 1" WATER CONNECTIONS
2	ALL	1	L	*2C212	OIL COOLER, CUPRO-NICKEL, 1" WATER CONN.
2	ALL	1	L	*2C212Z	OIL COOLER, CUPRO-NICKEL, 1" WATER CONNECTIONS WITH ZINC ANODE
2	ALL	1	L	*2C220	OIL COOLER, COPPER, 1-3/4" WATER CONNECTIONS. USE WITH KEEL COOLER APPLICATIONS.
2	I	1	F	1A228	OIL COOLER TURBO
3	ALL	1	L	3L1	PLUG, DRAIN, 1/8 NPT
4	ALL	1	L	2M3	OIL COOLER BRACKET, LOWER
5	ALL	1	L	2M4	OIL COOLER BRACKET, UPPER
6	ALL	1	L	OE101	BOLT, HEX. HD., 1/4-20 x 5/8"
7	ALL	1	L	OC21	LOCKWASHER, 1/4"
8	ALL	1	L	OB16	NUT, HEX., 1/4-20
9	ALL	1	L	2N50	ELEMENT, OIL FILTER
10	ALL	1	L	3C450	NIPPLE, 11/16 x 1 1/4"
11	ALL	1	L	1A312	BASE, OIL FILTER

* INCLUDES KEY 3 THRU 8

KEY	ENGINE	QUAN	CODE	PART NO.	DESCRIPTION
12	ALL	1	L	2D29	GASKET OIL PLATE
13	ALL	1	L	1A309	PLATE, OIL TAKE-OFF (580)
14	ALL	2	L	OE403	BOLT, 7/16-14 X 1 1/4"
15	ALL	2	L	OC51	LOCKWASHER, 7/16"
16	ALL	2	L	3D24	ELBOW, STREET, 3/8"
17	EG	3	L	3K760	HOSE, OIL, 13 1/2"
17	FH	1	L	3K760	HOSE, OIL, 13 1/2"
17	FH	2	L	3K764	HOSE, OIL, 17"
17	I	2	L	3K773	HOSE 18 1/2"
18	ALL	1	L	OE402	BOLT 7/16-14 x 1"
19	ALL	1	L	OC51	WASHER 7/16"

VENT TUBE ASSEMBLY

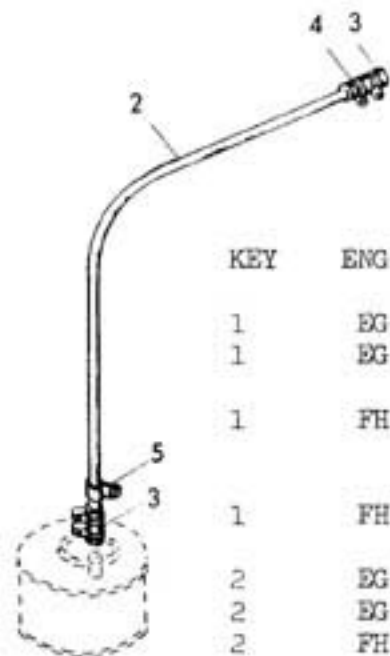

KEY No. 1 - Complete Assembly

KEY	ENGINE	QUAN	CODE	PART NO.	DESCRIPTION
1	EG	1	L	D1412	VENT TUBE (START AUG. '72)
1	EG	1	L	D1409	VENT TUBE ASSY. DISCONTINUED AUG. '72). NOTE 2.
1	FH	1	L	D1411	VENT TUBE ASSY. (FOR USE WITH SMOKE CONTROL VALVE ON ROCKER COVER).
1	FH	1	L	D1407	VENT TUBE ASSY. (NOTE 1)
2	EG	1	L	3K204A-13	HOSE, 1/2" ID x 13"
2	EG	1	L	1G145	TUBE, VENT (NOTE 1)
2	FH	1	L	1G146	TUBE, VENT
3	ALL	2	L	3K204A-1.25	HOSE, 1/2" ID x 1 1/4"
3	EG	1	L	3K204A-2.5	HOSE, 1/2" ID x 2 1/2"
4	FH	2/4	L	3K10	CLAMP, HOSE
5	ALL	1	L	2M9	CLIP
*	EG	1	L	3E372	ELBOW, COPPER. (NOTE 1)

NOTE 1 - THESE PARTS USED ON ENGINES NOT EQUIPPED WITH SMOKE CONTROL VALVE ON ROCKER COVER.

NOTE 2 - CONNECTS TO UNDERSIDE OF MANIFOLD. USES FORMED COPPER TUBE, ADAPTOR AND SHORT CONNECTING HOSE.

PUMP, RAW WATER

KEY NO. 1 - COMPLETE PUMP ASSEMBLY

KEY No. 2 - SERVICE KIT. Includes items marked ●

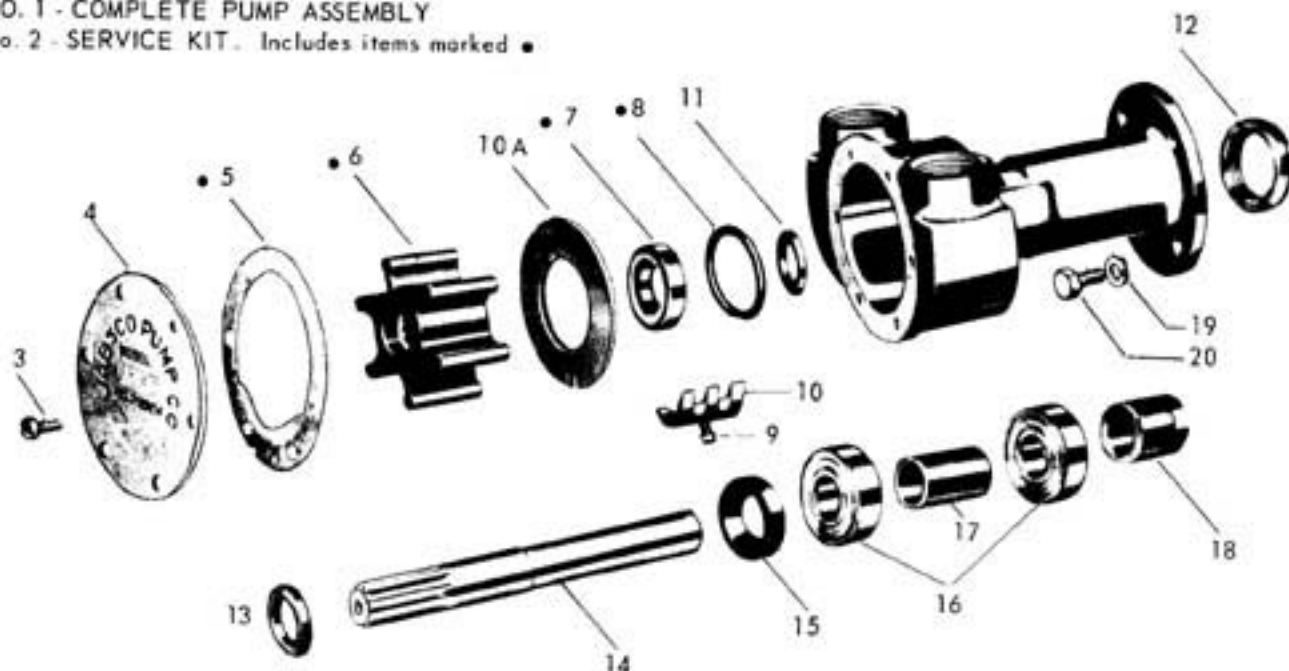

KEY	ENGINE	QUAN	CODE	PART NO.	DESCRIPTION
1	ALL	1	L	2C45	PUMP, RAW WATER
2	ALL	1	T	90033-0001	SERVICE KIT. INCLUDES ITEMS MARKED ●
3	ALL	6	T	91002-0020	SCREW, END COVER
4	ALL	1	T	11830-0000	END COVER
5	ALL	1	T	3298-0000	● GASKET
6	ALL	1	T	1210-0003	● IMPELLER
7	ALL	1	T	92700-0060	● SEAL, SHAFT
8	ALL	1	T	92000-0210	● O RING
9	ALL	1	T	91003-0010	CAM SCREW
10	ALL	1	T	7884-0000	CAM & WEARPLATE ASSY. (INCLUDES KEY 9 & 10A)
10A	ALL	1	T		WEARPLATE (SUPPLIED WITH KEY 10 CAM, ONLY)
11	ALL	1	T	3166-0000	SEAL SPACER
12	ALL	1	T	3376-0000	ADAPTOR RING
13	ALL	1	T	3286-0000	SLINGER
14	ALL	1	T	5857-0000	SHAFT
15	ALL	1	T	92700-0180	BEARING SEAL, INNER
16	ALL	2	T	92600-0130	BEARING
17	ALL	1	T	3383-0000	BEARING SPACER
18	ALL	1	T	3278-0000	COUPLING
19	ALL	4	L	0C-21	LOCKWASHER, 1/4"
20	ALL	4	L	0E102	BOLT, 1/4-20 x 3/4"

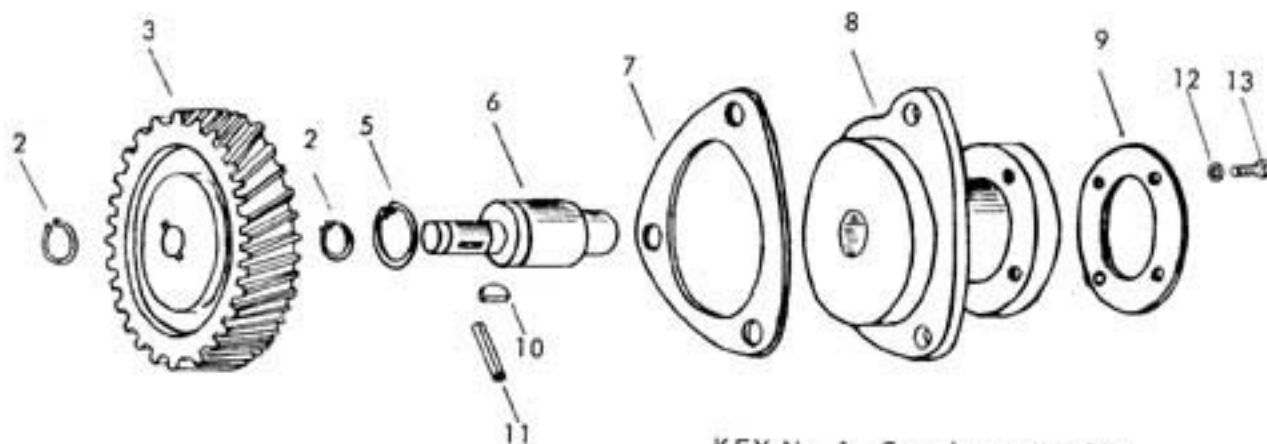

KEY No. 1 - Complete assembly

KEY	ENGINE	QUAN	CODE	PART NO.	DESCRIPTION
1	ALL	1	L	D-365	PUMP ADAPTOR & GEAR DRIVE ASSY.
2	ALL	2	L	2M100	SNAP RING, 5/8"
3	ALL	1	L	2B101	GEAR
5	ALL	1	L	2M101	SNAP RING, 1 3/16"
6	ALL	1	L	2G13/1B60	BALL BEARING & COUPLING ASSY.
7	ALL	1	L	1C33	GASKET, ADAPTOR MOUNTING
8	ALL	1	L	1A327	HOUSING (609)
9	ALL	1	L	1C34	GASKET, PUMP MOUNTING
10	ALL	1	L	2K5	WOODRUFF KEY (NOTE 1)
11	ALL	1	L	2K213	ROLL PIN, 3/16 x 3/4 (NOTE 2)
12	ALL	4	L	OC21	LOCKWASHER, 1/4"
13	ALL	4	L	OE102	BOLT, 1/4-20 x 3/4"

NOTE 1) USED UNTIL JUNE 1972

NOTE 2) USED FROM JUNE 1972

RAW WATER PIPING

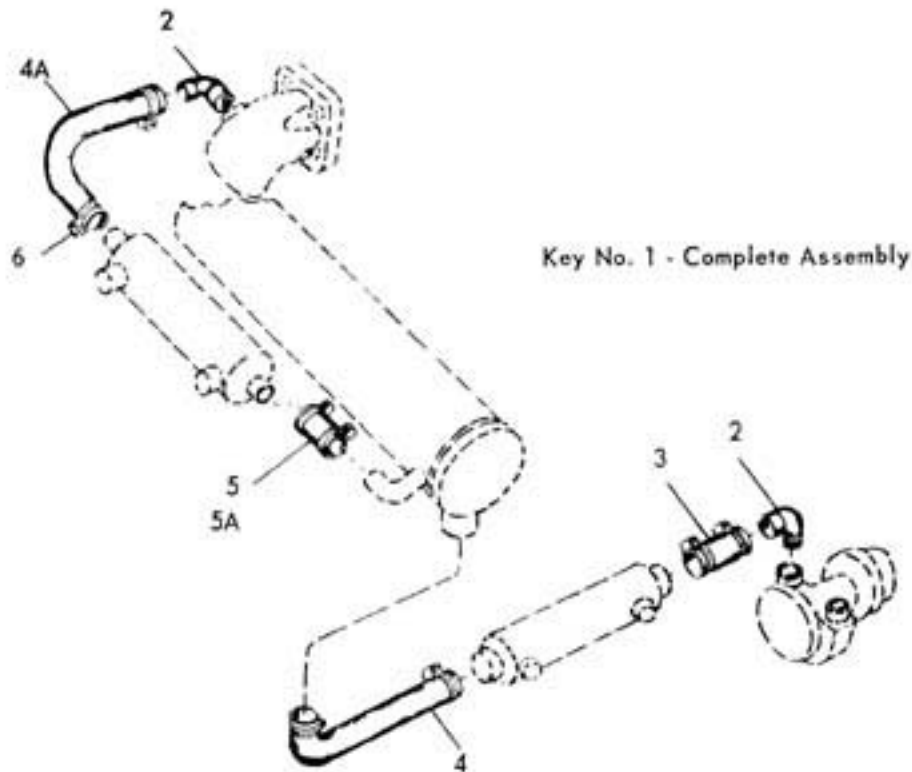

KEY	ENGINE	QUAN	CODE	PART NO.	DESCRIPTION
1	EG	1	L	D1490	RAW WATER PIPING
1	FHI	1	L	D894	RAW WATER PIPING
2	ALL	2	L	3E856	ELBOW, 3/4 NPT x 1" HOSE
3	EG	1	L	EW62-12	HOSE, 1" ID x 12"
3	PH	1	L	3K207A-5	HOSE, 1" ID x 5"
4	EG	1	L	3K816	MOLDED HOSE (NOTE 1)
4	FH	1	L	3K817	MOLDED HOSE (NOTE 1)
4A	ALL	1	L	3K818	MOLDED HOSE (NOTE 1)
5	FH	1	L	3K207A-2.25	HOSE, 1" ID x 2-1/4"
5A	EG	1	L	3K815	MOLDED HOSE (NOTE 1)
6	ALL	8	L	3K2	CLAMP, HOSE

NOTE: 3K351 MOLDED HOSE TO BE CUT TO FIT APPLICATION. ONE HOSE 3K351 WILL MAKE 2 90° ELBOWS AS USED FOR KEY 4, 4A or 5A.

ENGINE SUPPORTS

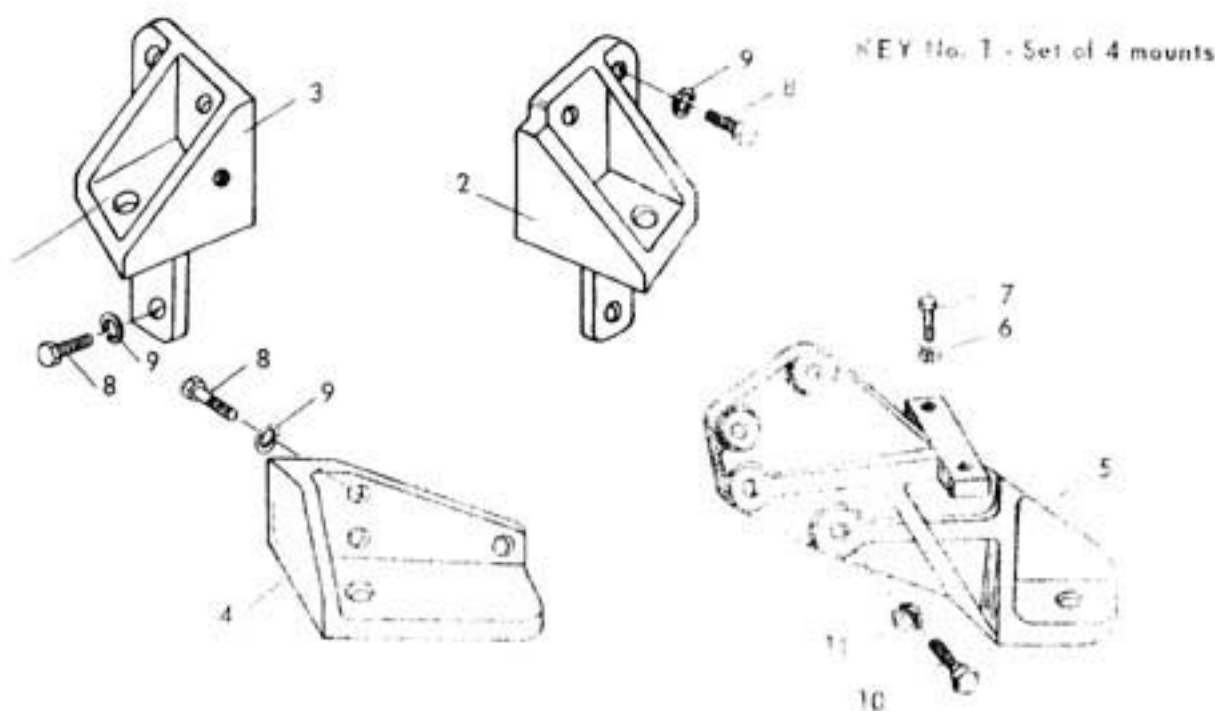

KEY	ENGINE	QUAN	CODE	PART NO.	DESCRIPTION
1	ALL	1	L	D504	ENGINE SUPPORTS (SET OF 4)
2	ALL	1	L	1A327	SUPPORT, LEFT REAR (600)
3	ALL	1	L	1A332	SUPPORT, RIGHT REAR (600)
4	ALL	1	L	1A329	SUPPORT, RIGHT FRONT (600)
5	ALL	1	L	1A330	SUPPORT, LEFT FRONT (610)
6	ALL	2	L	0C31	LOCKWASHER, 5/16"
7	ALL	2	L	0E201	BOLT, 5/16-18 x 3/4"
8	ALL	9	L	0E403	BOLT, 7/16-14 x 1 1/4"
9	ALL	9	L	0C51	LOCKWASHER, 7/16"
10	ALL	4	L	0E303-C	BOLT, 3/8-16 x 1 1/4"
11	ALL	4	L	0C41	LOCKWASHER, 3/8"

(FLEXIBLE) ENGINE MOUNTS

- ALL 4 L 2M1 ENGINE MOUNT, USED TO JUNE 1974.
(Identify by casting height 1 1/4")
- ALL 4 L 2M5 ENGINE MOUNT, USED FROM JUNE 1974.
(Identify by casting height 1 1/2")

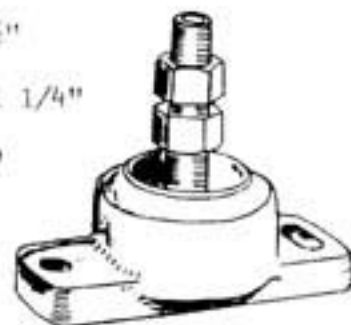

TRANSMISSION ADAPTION ASSEMBLY

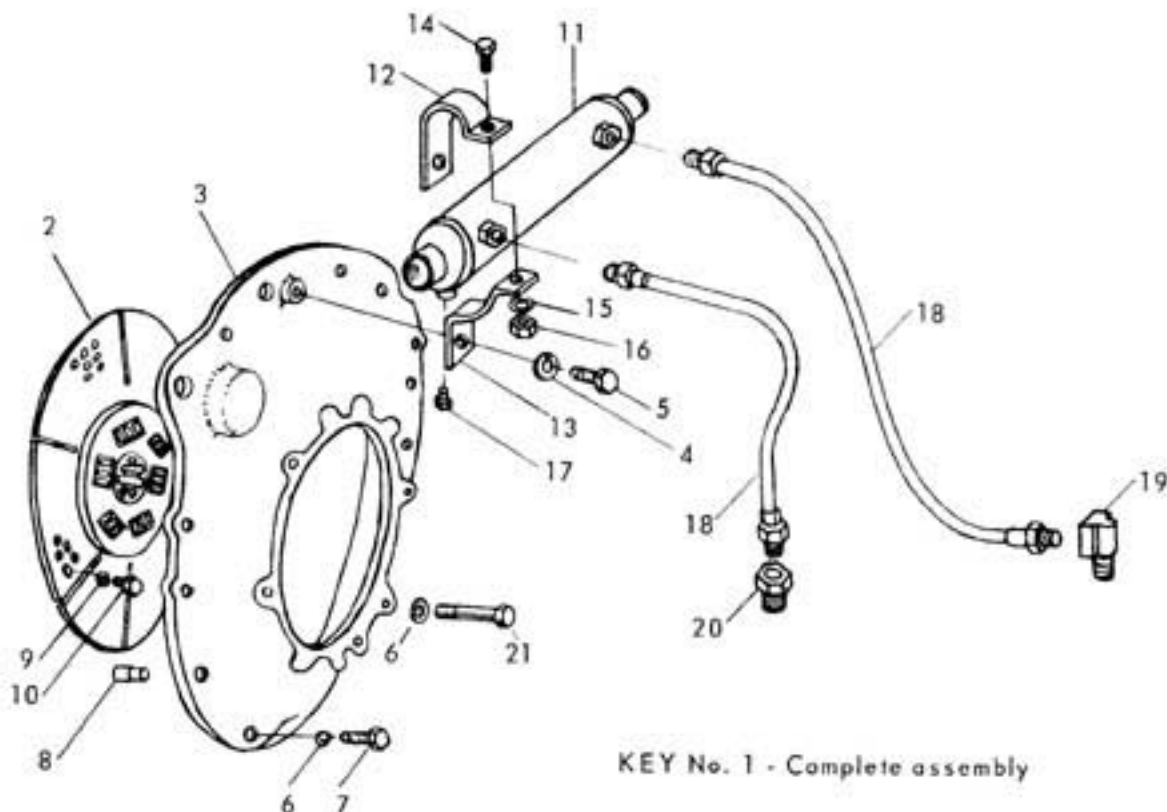

KEY No. 1 - Complete assembly

KEY	ENGINE	QUAN.	CODE	PART NO.	DESCRIPTION
1	ALL	1	L	D141-W	ADAPTION ASSY. FOR WARNER TRANSMISSIONS
1	ALL	1	L	D141-P	ADAPTION ASSY. FOR PARAGON TRANSMISSIONS
2	ALL	1	L	2L7	DRIVE DAMPER
3	ALL	1	L	1A285	ADAPTOR (5+8)
4	ALL	1	L	OC41	LOCKWASHER, 3/8"
5	ALL	1	L	OE302	BOLT, HEX. HD., 3/8-16 x 1"
6	ALL	21	L	OC51	LOCKWASHER, 7/16"
7	ALL	15	L	OE403	BOLT, HEX. HD., 7/16-14 x 1 1/4"
8	ALL	2	L	2K207	DOWEL
9	ALL	3	L	OC31	LOCKWASHER, 5/16"
10	ALL	3	L	OE201-C	BOLT, HEX. HD., 5/16-18 x 3/4"
11	ALL	1	L	2C207	OIL COOLER (COPPER) 1" WATER CONNECTIONS
11	ALL	1	L	2C212	OIL COOLER (CUPRO-NICKEL) 1" WATER CONN.
11	ALL	1	L	2C212-Z	OIL COOLER (CUPRO-NICKEL) 1" WATER CONNECTIONS & ZINC ANODE
11	ALL	1	L	2C220	OIL COOLER (COPPER) 1 3/4" WATER CONNECTIONS. FOR USE WITH KEEL COOLER.
12	ALL	1	L	2M3	OIL COOLER BRACKET, UPPER

KEY	ENGINE	QUAN	CODE	PART NO.	DESCRIPTION
13	ALL	1	L	2M4	OIL COOLER BRACKET, LOWER
14	ALL	1	L	OE101	BOLT, 1/4-20 x 5/8"
15	ALL	1	L	OC21	LOCKWASHER, 1/4"
16	ALL	1	L	OB16	NUT, 1/4-20
17	ALL	1	L	3L1	PLUG, DRAIN, 1/8 NPT
18	ALL	A/R	L	3K760	HOSE, OIL, 13 1/2"
18	ALL	A/R	L	3K764	HOSE, OIL, 17"
18	ALL	A/R	L	3K772	HOSE, OIL, 22"
19	ALL	A/R	L	3D24	ELBOW, STREET, 3/8 NPT
20	ALL	1	L	3G25	ADAPTOR BUSHING, 3/8 x 3/8 NPT
21	ALL	6	L	OE409	BOLT, 7/16-14 x 3 1/2" (FOR WARNER)
21	ALL	6	L	OE405	BOLT, 7/16-14 x 1 3/4" (FOR PARAGON)

APERTURE COVER

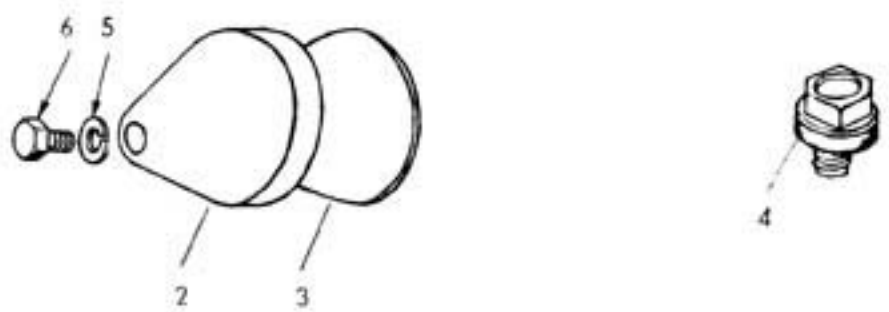

KEY	ENGINE	QUAN	CODE	PART NO.	DESCRIPTION
1	ALL	1	L	D231	APERTURE COVER ASSY.
2	ALL	1	L	1A239	COVER (463)
3	ALL	1	L	1C28	GASKET
4	ALL	1	L	OE290	PLUG ASSY.
5	ALL	1	L	OC31	LOCKWASHER
6	ALL	1	L	OE201	BOLT, 5/16-18 x 3/4"

D-1265 STARTER RELAY/SOLENOID ASSEMBLY

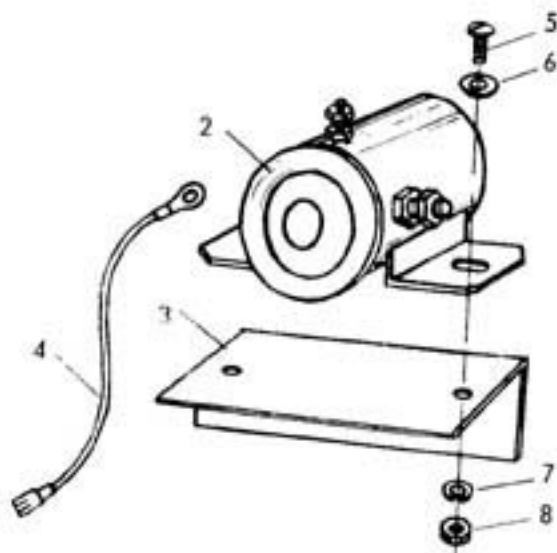

KEY	ENGINE	QUAN	CODE	PART NO.	DESCRIPTION
1	ALL	1	L	D1265	STARTER SOLENOID/RELAY ASSY. (INCLUDES ALL FOLLOWING PARTS)
2	ALL	1	L	2E202	SOLENOID
3	ALL	1	L	1D2	ANGLE, SUPPORT
4	ALL	1	L	2E402	WIRE ASSY. (W/2 RING TERMINALS)
4	ALL	1	L	2E403	WIRE ASSY. (W/1 RING; 1 BAYONET TERMINAL)
5	ALL	2	L	0A4	MACHINE SCREW #10-32 x 1/2"
6	ALL	2	L	0C10	FLAT WASHER, 3/16"
7	ALL	2	L	0C5	LOCKWASHER, #10
8	ALL	2	L	0B1	NUT #10-32
				4C59	INSTRUCTIONS

KEY	ENGINE	QUAN	CODE	PART NO.	DESCRIPTION
1	EFGH	1	L	D895	HOSE ASSY. (WITH CLAMPS)
2	ALL	1	L	3K507	HOSE, MOLDED
*	ALL	1	L	3K213-B	SPRING INSERT
3	ALL	2	L	3K4	CLAMP

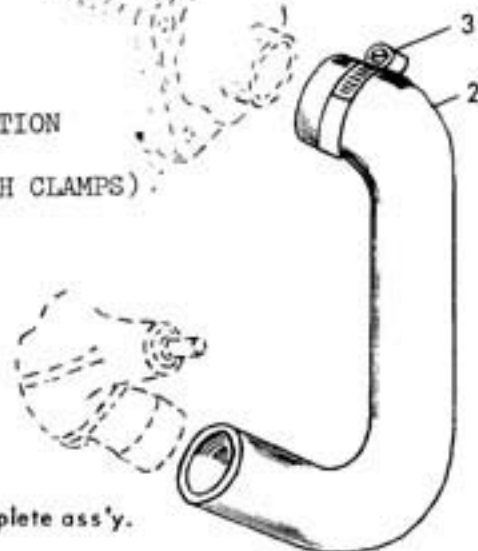

Key No. 1 - Complete ass'y.



KEY	ENGINE	QUAN	CODE	PART NO.	DESCRIPTION
1	ALL	1	L	D798	FUEL LINE, 9" LONG (INCLUDES KEY 2)
1	ALL	1	L	D799	FUEL LINE, 15" LONG (INCLUDES KEY 2)
1	ALL	1	L	D799-AA	FUEL LINE, 36" LONG
2	ALL	1	L	3E18	NUT, FUEL LINE

MISCELLANEOUS EQUIPMENT

KEY	ENGINE	QUAN	CODE	PART NO.	DESCRIPTION
	ALL	4	L	1D12	RING, LIFTING
	EG	2	L	2H52	AIR FILTER, 2 9/16" BOLT SPACING. (USED UNTIL AUGUST 1972)
	EG	2	L	2H54	AIR FILTER, 2 7/8" BOLT SPACING. (USED FROM AUG. 1972) WITH 1F3 ELEMENT.
	EG	2	L	1F4	FILTER ELEMENT ONLY
	FH	1	L	2H53	AIR FILTER (WITH 1F1 ELEMENT)
	FH	1	L	1F1	FILTER ELEMENT ONLY
	ALL	1	L	2B209	VEE BELT
		A/R	L	EM103	PAINT, TOUCH-UP RED, 13 OZ. SPRAY CAN.

OPTIONAL EQUIPMENT

EK28 and EK28-A THROTTLE and STOP CONTROL HARDWARE KITS

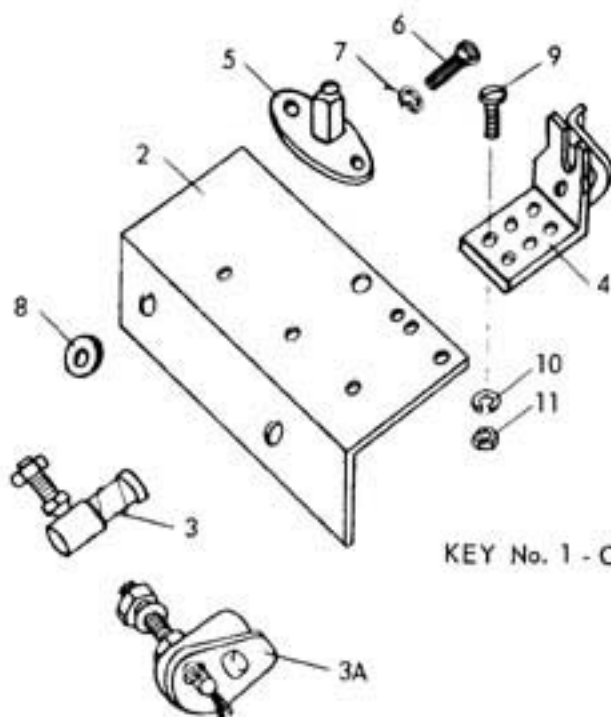

KEY No. 1 - Complete assembly

KEY	ENGINE	QUAN	CODE	PART NO.	DESCRIPTION
1	ALL	1	L	EK28	THROTTLE AND STOP CONTROL ASSY.
1	ALL	1	L	EK28-A	DUAL THROTTLE AND STOP CONTROL ASSY.
2	ALL	1	L	1D40	ANGLE BRACKET
3	ALL	1	L	EC103	BALL JOINT (FOR SINGLE CONTROL)
3A	ALL	1	L	EC163	CABLE CONNECTORS (FOR DUAL CONTROL)*
4	ALL	1	L	EC104	ALSO INCLUDES EC110--SEE BELOW
4	ALL	1	L	* EC110	CABLE CLAMP (FOR SINGLE CONTROL)
					CABLE CLAMP (FOR DUAL CONTROL)
5	ALL	1	L	EC76	STOP CABLE CLAMP
6	ALL	2	L	OE202	BOLT, 5/16-18 x 1"
7	ALL	2	L	OC31	LOCKWASHER, 5/16
8	ALL	6	L	OC30	FLAT WASHER, 5/16
9	ALL	4	L	OA3	MACHINE SCREW, #10-32 x 3/8"
10	ALL	4	L	OC5	LOCKWASHER #10
11	ALL	4	L	OB1	NUT, #10-32
				4C51	INSTRUCTIONS

D-1266 ELECTRIC STOP AND THROTTLE CONNECTION KIT

KEY	ENGINE	QUAN	CODE	PART NO.	DESCRIPTION
1	ALL	1	L	D1266	ELECTRIC STOP CONTROL AND THROTTLE CONNECTION KIT.
1	ALL	1	L	D1266-A	SAME-FOR DUAL STATION
2	ALL	1	L	2E210	SOLENOID
2A	ALL	1	L	2E211	SOLENOID, NEW STYLE
3	ALL	1	L	1B65	ROD, CONNECTING
4	ALL	1	L	EC103	BALL JOINT
5	ALL	1	L	2K353	COTTER, 1/16 x 1/2"
6	ALL	1	L	OC11	FLAT WASHER, 3/16"
7	ALL	1	L	1D44	ANGLE BRACKET, UPPER
8	ALL	1	L	1D40	ANGLE BRACKET, LOWER
9	ALL	1	L	EC103	BALL JOINT (FOR SINGLE CONTROL)
9A	ALL	1	L	EC163	CABLE CONNECTORS (FOR DUAL CONTROLS)
10	ALL	1	L	EC104	CABLE CLAMP (FOR SINGLE CONTROL)
10	ALL	1	L	EC110	CABLE CLAMP (FOR DUAL CONTROLS)
11	ALL	2	L	OE202	BOLT, 5/16-18 x 1"
12	ALL	2	L	OC31	LOCKWASHER, 5/16"
13	ALL	6	L	OC30	FLAT WASHER, 5/16"
14	ALL	1	L	OE101	BOLT, 1/4-20 x 5/8"
15	ALL	1	L	OC21	LOCKWASHER, 1/4"
16	ALL	1	L	OB16	NUT, 1/4-20
17	ALL	4	L	OA4	MACHINE SCREW #10-32 x 1/2"
18	ALL	4	L	OC5	LOCKWASHER #10
19	ALL	4	L	OB1	NUT, #10-32

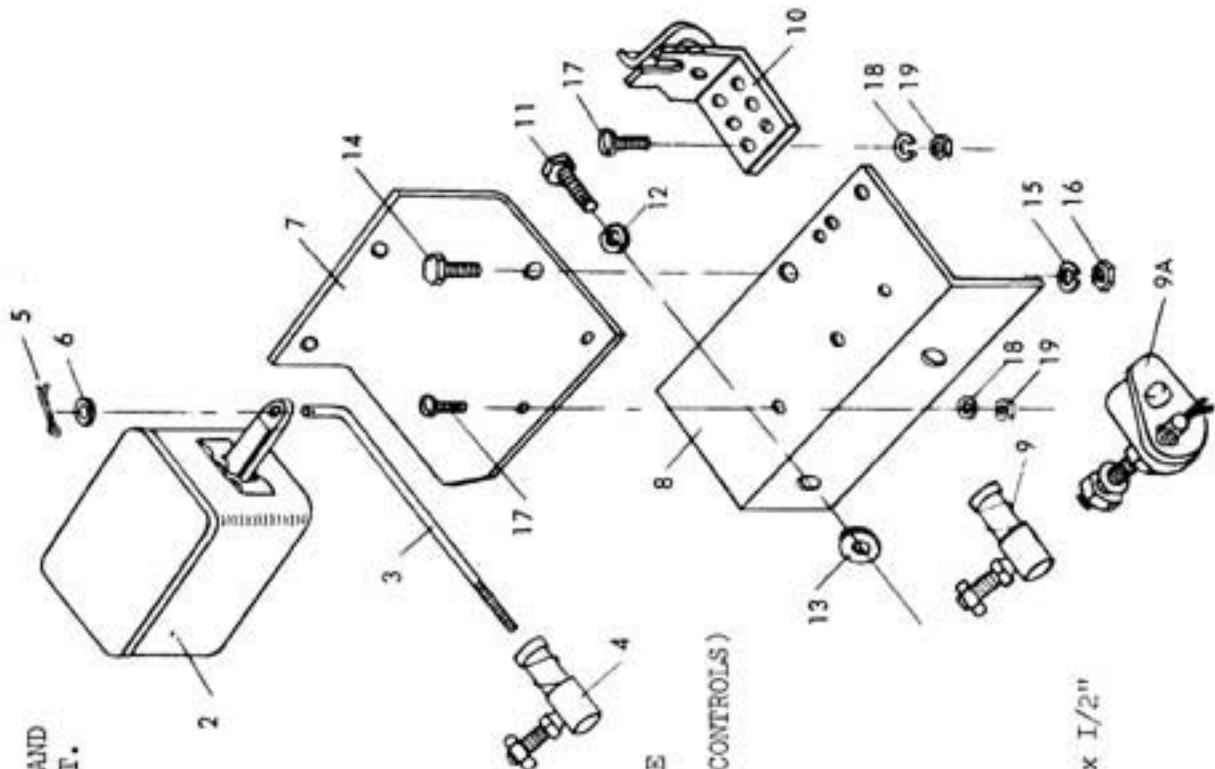

OPTIONAL EQUIPMENT
D-1130 EXHAUST RISER ASSEMBLY

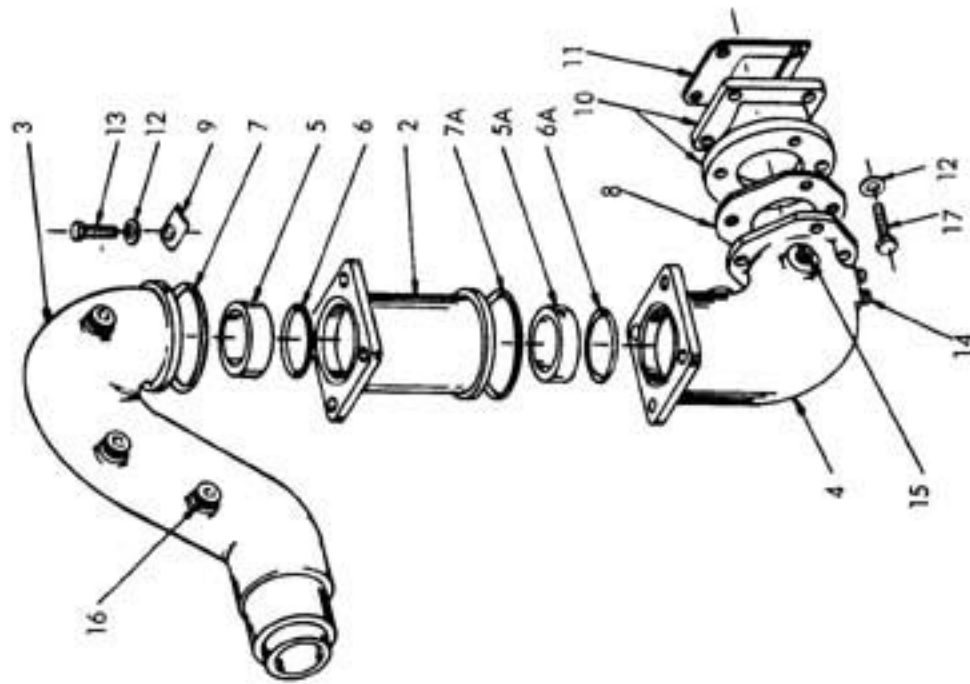

Key No. 1 - Complete riser assembly
Key No. 2 - Extension assembly

KEY	ENGINE	QUAN	CODE	PART NO.	DESCRIPTION
1	ALL	1	L	D1130	RISER ASSEMBLY. CONSISTS OF KEY NUMBERS 3 THROUGH 17.
2	ALL	1	L	EE25	RISER EXTENSION ASSEMBLY. CONSISTS OF KEY NUMBERS 2 AND 5A THROUGH 7A.
3	ALL	1	L	EE24--A	GOOSENECK
4	ALL	1	L	EE24--B	ELBOW
5	ALL	1	L	EE24--C	SLEEVE
6	ALL	1	L	EE24--D	O RING (SMALL)
7	ALL	1	L	EE24--E	O RING (LARGE)
8	ALL	1	L	EE24--F	GASKET
9	ALL	4	L	EE24--G	RETAINER
10	ALL	1	L	1A348	ADAPTOR, MANIFOLD (669)
11	ALL	1	L	1C26	GASKET
12	ALL	8	L	0C41	LOCKWASHER, 3/8"
13	ALL	4	L	OE303-C	BOLT, 3/8 x 1 1/4
14	ALL	2	L	3L10	PLUG, 1/4"
15	ALL	2	L	3L31	PLUG, 1/2"
16	ALL	4	L	3L41	PLUG, 3/4"
17	ALL	4	L	OE302-C	BOLT, 3/8 x 1 1/4

OPTIONAL EQUIPMENT
EK31 and EK32 ALARM SYSTEMS

<u>CODE</u>	<u>PART</u>	<u>DESCRIPTION</u>
L	EG302	OIL ALARM SENDING UNIT, 1/8" NPT
L	3G9	BUSHING, 1/8 x 3/8 NPT
L	EG403	ALARM TEMPERATURE SENDER, 3/8" NPT
L	EI600	RELAY
L	EI601	BUZZER

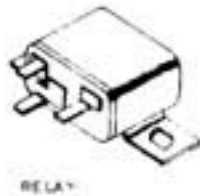
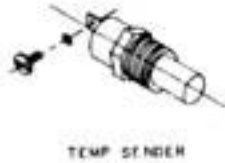

OPTIONAL EQUIPMENT
D1495-A WATER HEATER CONNECTION KIT

KEY	CODE	PART No.	DESCRIPTION	2
1	L	D1495-A	WATER HEATER CONNECTION KIT	
2	L	2C303	HOSE SLEEVE	
3	L	3K4	CLAMP, HOSE	
4	L	3B499-A	ADAPTOR	
5	L	3F12	TEE	
*	L	4C68	INSTRUCTIONS	

KEY No. 1 - Complete kit

*** ON BOARD * SPARE PARTS KITS**

The prudent boatman will stow spare engine parts aboard his vessel to be used in the event of emergency.

Ordinarily it is not practical to perform major engine repairs on a small vessel at sea, but such parts as hoses, vee belts, filter elements, etc. which may be serviced and which, upon failure, could cause engine failure, should certainly be carried aboard. For this purpose the following "Limited Cruising Kits" are offered.

For the vessel that may range to distant or foreign ports away from lines of communication or transportation, consideration should be given to stowage of additional parts. For such use the "Extended Cruising Range Kits" are available.

LIMITED CRUISING RANGE KITS include: complete set of fuel injection pipes; thermostat; end gaskets for manifold and exchanger; zinc pencil element; raw water pump impeller; lube oil filter element; fuel filter element; vee belt; complete set of hoses.

KIT No. 105 for 6D363 6 cylinder engines equipped with CAV injection pump

KIT No. 109 for 6D363 and 6D380 engines equipped with Simms injection pump

KIT No. 107 for 4D242 and 4D254 4 cylinder engines.

EXTENDED CRUISING RANGE KITS include: All parts as listed above for limited cruising range kits except for raw water pump impeller and fuel lift pump rebuild kit. Additional items include: complete gasket (overhaul) set (excepting transmission); complete injector; injector removal tool; complete fresh water pump; complete fuel supply (lift) pump; raw water pump overhaul kit.

Kit No. 106 for 6D363 6 cylinder engine equipped with CAV injection pump.

Kit No. 108 for 4D242 or 4D254 4 cylinder engines.

Kit No. 110 for 6D363 6 cylinder engines equipped with Simms injection pump.

Kit No. 110-A for all 6D380 6 cylinder engines.

MANUALS, PARTS LISTS, Etc.

ENGINE	CODE	PART NO.	DESCRIPTION
ALL	F	4C62	FORD ENGINE REBUILDING (SHOP) MANUAL
TRANSMISSION	P	4C69	PARAGON G31 & G33 (LEHMAN 144)
TRANSMISSION	P	4C70	PARAGON P30 & P40 SERIES (LEHMAN 155 & 156)
TRANSMISSION	W	4C71	WARNER 71 (LEHMAN 71) TRANSMISSION ONLY
TRANSMISSION	W	4C72	WARNER 72 (LEHMAN 72) TRANSMISSION ONLY
TRANSMISSION	W	4C73	WARNER 73 (LEHMAN 73) TRANSMISSION (DIRECT DRIVE & REDUCTION)
TRANSMISSION	W	4C74	WARNER 1.5 REDUCTIONS ONLY
TRANSMISSION	W	4C75	WARNER 1.9 REDUCTIONS ONLY
TRANSMISSION	W	4C76	WARNER 2.1 REDUCTIONS ONLY
TRANSMISSION	W	4C77	WARNER 2.5 & 2.9 REDUCTIONS ONLY
TRANSMISSION	W	4C78	WARNER VEE DRIVE (ALL RATIOS)
TRANSMISSION	W	4C79	WARNER DROP CENTER (LEHMAN 161 & 162) TRANSMISSION & REDUCTIONS
TRANSMISSION	W	4C80	WARNER GENERAL INSTALLATION MANUAL